

WaveShaper A-Series User Manual

FINISAR®



Revision A00

The WaveShaper Help covers the general operation of the WaveShaper Series 'A' products and the WaveShaper 1.4 software package which includes the WaveShaper App and the WaveShaper Webserver.

It is not valid for other hardware or software versions.

For information about the WaveShaper Series 'A' range, please visit the Finisar Optical Instrumentation website.

For detailed technical help, please visit the Finisar KnowledgeBase website. (www.finisarknowledgebase.com)

FINISAR[®]

© Finisar 2013 – 2020

Contents

Section 1	Overview	4
1.1	Safety Considerations	4
1.2	LCoS Introduction	5
1.3	Optical Design	5
Section 2	Connecting via Ethernet	6
2.1	Connecting to the Waveshaper	6
2.2	Ethernet Connection	6
2.3	Webserver Browser Interface	7
2.4	Can't find the WaveShaper?	8
2.5	WaveShaper Mac Address	8
Section 3	Graphical User Interface	9
3.1	Filter	9
3.6	Sketch	13
3.12	Pulse Shaping	20
3.17	Tools	24
3.24	Power Splitting	28
Section 4	Defining Optical Filters	30
4.1	Optical Filter Files	30
4.2	User Configured Filters (*.ucf)	30
4.3	WaveShaper Presets (*.wsp)	31
Section 5	Programming	35
5.1	RESTful Interface	35
5.2	HTTP API Basics	36
5.3	Programming Examples	37
5.4	Python Examples	38
5.5	MATLAB Examples	39
5.6	LabVIEW Examples	41
5.7	Power Splitting Programming	42
Section 6	Specifications	44
6.1	Optical Specifications	44
6.2	Electrical Specifications	45
6.3	Environmental Conditions	46

Section 1 Overview

1.1 Safety Considerations

The following general safety precautions must be observed during all phases of operation, service, and repair of this module. Failure to comply with these precautions or with specific warnings elsewhere in this manual violates safety standards of design, manufacture, and intended use of the instrument. Finisar assumes no liability for the failure to comply with these requirements.

This product has been designed in accordance with IEC Publication 61010-1, Safety Requirements for Electrical Equipment for Measurement, Control and Laboratory Use, and IEC Publication 60825-1 Safety of Laser Products - Part 1: Equipment classification and requirements and has been supplied in a safe condition. This documentation contains information and warnings that must be followed by the user to ensure safe operation and to maintain the product in a safe condition. Before operation, you should review the instrument and manual for safety markings and instructions. You must follow these to ensure safe operation and to maintain the instrument in safe condition.

To avoid electrical shock, do not perform electrical tests when there are signs of shipping damage to any portion of the outer enclosure.

Laser Safety

The WaveShaper family of Programmable Optical Processors are designed for use with various classes of laser up to, and including, Class 3B lasers. Whilst the WaveShaper module does not generate laser light, laser light may be present on one or more output ports depending on the configuration of WaveShaper selected and the type of laser connected to the input port(s). Please pay attention to the following laser safety warnings:

- ◆ Under no circumstances look into the end of an optical output cable/connector(s) when the device is operational. If there is any laser radiation it could seriously damage your eyesight.
- ◆ Do not operate the WaveShaper without attaching the optical output connector(s) to a safely terminated mating connector(s).
- ◆ Refer servicing only to qualified and authorized Finisar personnel.

Electrical Safety

The mains-powered versions of the WaveShaper require single-phase AC, 100–240V, 50–60Hz and has a maximum power consumption of 50VA. In accordance with international safety standards, the instrument has a three-wire power cable. When connected to an appropriate AC power receptacle, this cable earths the instrument chassis. To avoid the possibility of injury or death, you must observe the following precautions before switching on the instrument.

- ◆ Insert the power cable plug only into a socket outlet provided with a protective earth contact. Do not negate this protective action by using an extension cord or power block without a protective conductor.
- ◆ Do not interrupt the protective earth connection intentionally.
- ◆ Do not remove protective covers. Operating personnel must not remove instrument covers. The unit contains no user-serviceable components. Component replacement and internal adjustments must be made only by qualified Finisar service personnel.
- ◆ A WaveShaper chassis that appears damaged or defective should be made inoperative and secured against unintended operation until it can be repaired by qualified Finisar service personnel.
- ◆ A defective, damaged, or malfunctioning WaveShaper chassis must be returned to Finisar for repair.

The module versions of the WaveShaper are designed to operate from a user-supplied +5V supply.

- ◆ The module contains Electrostatic Discharge Sensitive Devices.
- ◆ Operating personnel must not remove the module lid. The module contains no user-serviceable components. Component replacement and internal adjustments must be made only by qualified Finisar service personnel.
- ◆ A WaveShaper module that appears damaged or defective should be made inoperative and secured against unintended operation until it can be repaired by qualified Finisar service personnel.

The module is supplied with a mating Phoenix power plug which needs to be wired to a power supply capable of providing +5V to +5.6V at a current of at least 8A. The wire used should be red for +5V and black for 0V 22AWG (0.5mm,16/0.2,Tri-rated PVC insulated UL1015).

1.2 LCoS Introduction

Conventional liquid crystal components used in telecom applications employ control of polarisation state to pass or transmit light to create for example wavelength blockers or attenuators. Switching applications can be achieved through polarisation dependent deflection or displacement. These designs are limited by having inflexible configurations – typically with one pixel per channel – and the requirement to preconfigure the channel plan in advance.

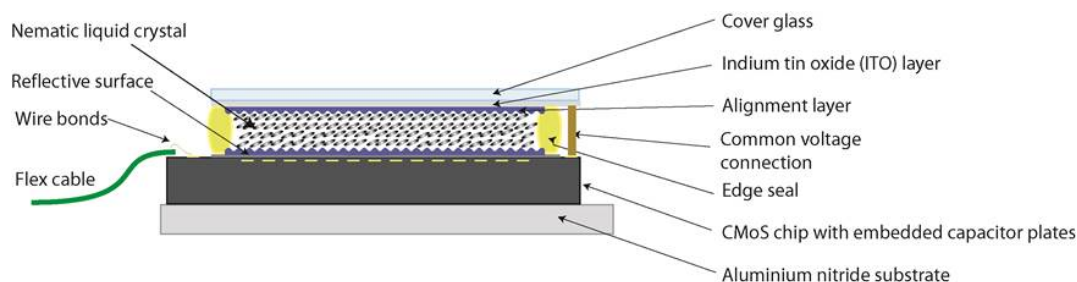

Liquid Crystal on Silicon (LCoS) is a display technology which combines Liquid Crystal and semiconductor technologies, to create a high resolution, solid-state display engine. The diagram shows the structure of an LCoS display with the Liquid Crystal (LC) layer sandwiched between the Active Matrix silicon backplane and the ITO-coated (Indium Titanium Oxide) top glass.

1.3 Optical Design

LCoS can be employed to control the phase of light at each pixel to produce beam steering. In the WaveShaper, a large number of phase steps are used to create a highly efficient, low-insertion loss switch shown schematically in this diagram. This simple optical design incorporates polarisation diversity, control of mode size and a 4-f wavelength optical imaging in the dispersive axis of the LCoS providing integrated switching and optical power control.

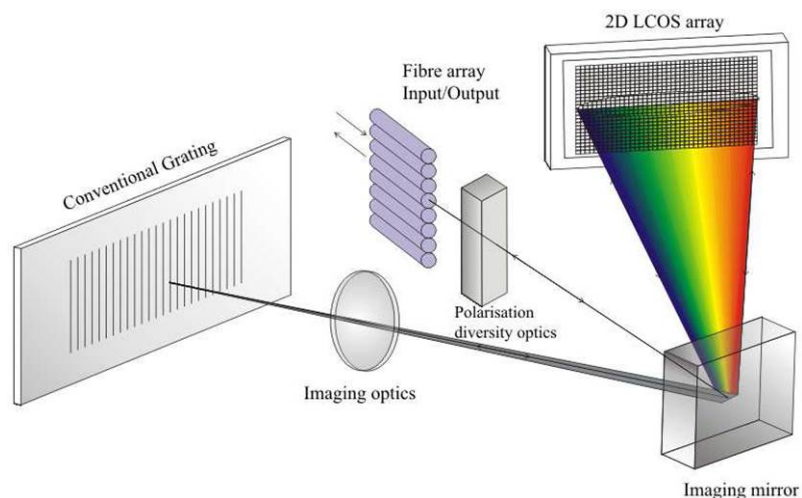

Light enters the device from a fibre array, and is then processed by polarisation diversity optics to align orthogonal polarisation states to maximize efficiency at the diffraction grating. The grating is designed to be at Littrow incidence, and angularly disperses the light to the LCoS array, where the reflected light is traced back through the system to the chosen output fibre, based on the beam-steering image programmed on the LCoS array.

As the wavelengths are separated on the LCoS the control of each wavelength is independent of all others and can be switched or filtered without interfering with other wavelengths.

Section 2 Connecting via Ethernet

2.1 Connecting to the Waveshaper

Connection to multiple Series A WaveShapers can be made through a LAN or Internet connection where each WaveShaper is addressed by a unique IP address. The connection is through http commands which make the control interface platform independent. Windows, OS X, Android, iOS, Linux, etc...are all supported.

All Series A WaveShapers can be controlled through one of four techniques:

- ◆ WaveShaper App Graphical User Interface (Ethernet only)
- ◆ RESTful HTTP Commands (Ethernet Only)
- ◆ WaveManager 2.7.4 and above (USB only, backward compatible)
- ◆ WaveShaper API (USB only, backward compatible)

This help document covers the WaveShaper App and RESTful HTTP Commands - for details on the WaveManager 2.7 and API, please see the relevant documentation on the Finisar website.

2.2 Ethernet Connection

There are two programs used to connect to the WaveShaper through the Ethernet port. The WaveShaper App is installed on Windows operating systems and the WaveShaper Webserver is installed on each Series 'A' WaveShaper for control through HTTP. Note that the App and Webserver are identical and vary only in the location that they are stored. The functionality for both is identical.

WaveShaper App

The WaveShaper App is a Windows program that will run on Windows 7, 8.1 and 10 systems. It can be installed from the USB drive that is supplied with the WaveShaper or it can be downloaded from the Finisar website.

When the program is run, the WaveShaper Connect window will open and run a search for any WaveShapers connected to the network.

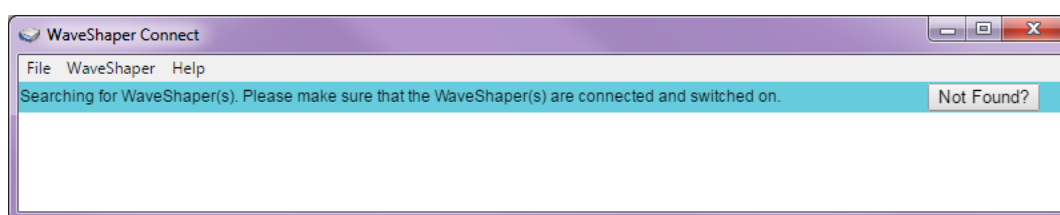

It will then show a list of WaveShapers currently connected to the network. The information shown will be the WaveShaper model number, serial number and IP address.

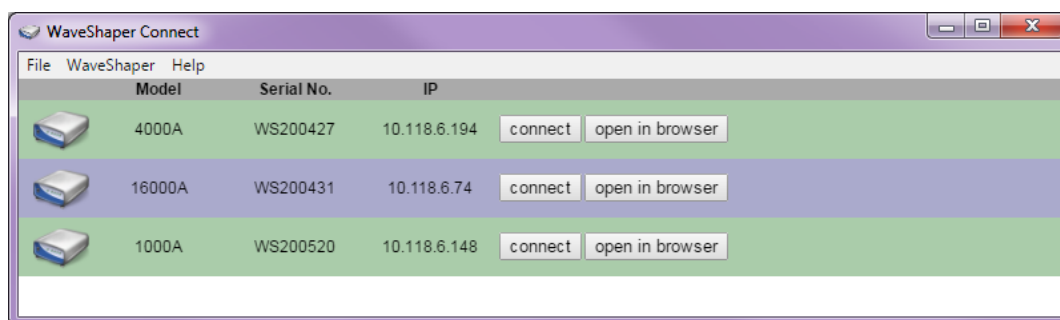

The "connect" button will open up the WaveShaper App which is a program built using HTML5 and JavaScript.

The "open in browser" button will connect to the webserver on the WaveShaper and it will open in the default web browser installed on the computer.

The WaveShaper App must be used to install any WaveShaper Firmware updates that may be required through the Tools option.

WaveShaper Not Found?

If the WaveShaper connected to the network does not appear then the "Not Found?" button will connect you to the connection troubleshooting section of the help file.

WaveShaper Connect Menu Options

The WaveShaper Connect contains a number of menu options.

- ◆ **File > Exit (Ctrl + E):** Shortcut to exit the WaveShaper Connect program.
- ◆ **WaveShaper > Custom IP Address:** Used to connect to a WaveShaper on the network that has a fixed IP address and is not discoverable through the WaveShaper Connect program. Type the IP address into the window then click on the connect button.



- ◆ **Help > Help:** Connects to a standalone help window showing the contents of the help file, without the icon ribbon of the WaveShaper App.
- ◆ **Help > Quickstart Guide:** Opens up a PDF version of the Quickstart Guide shipped with the WaveShaper.
- ◆ **Help > KnowledgeBase:** Connects to an online address that is dedicated to answering more technical questions about the WaveShaper and WaveAnalyzer family of products from the Optical Instrumentation Group of Finisar.
- ◆ **Help > About:** Shows the currently installed version number of the WaveShaper App.

2.3 Webserver Browser Interface

The WaveShaper Series A instruments contain an in-built webserver. Any operating system with a Web Browser can connect to the WaveShaper directly by sending HTTP commands directly to the unit. No dedicated software or drivers are required.

There are two addresses that can be used to connect to the WaveShaper.

- ◆ **mDNS address:** for example WS200427.local where the WS200427 is the serial number of the WaveShaper. Once connected, the IP address will appear in the address bar: <http://ws200427.local/waveshaper.html#/basic>
- ◆ **IP address:** for example typing 10.118.6.194 directly into the address bar. The IP address can be obtained by using the WaveShaper Connect program found when installing the WaveShaper App. Once connected, the IP address will appear in the address bar: <http://10.118.6.194/waveshaper.html#/basic>

The WaveShaper Webserver can be used in conjunction with the following browsers:

- ◆ Firefox
- ◆ Chrome
- ◆ Safari
- ◆ Internet Explorer version 11 and above
- ◆ Microsoft Edge

The WaveShaper can be controlled using the web browser on a hand-held device such as a tablet or phone. However, performance has been optimised for use with a mouse and keyboard and not all functions may operate correctly when used with a touchscreen device.

2.4 Can't find the WaveShaper?

If the WaveShaper connected to the network does not appear in the WaveShaper Connect window, then try these steps:

- ◆ Ensure that the WaveShaper is connected to the LAN **before** powering-on the instrument. The network will only assign an IP address to the WaveShaper if it is connected to the network before powering on. The default WaveShaper IP address may cause some issues in some network configurations.
- ◆ If the WaveShaper still does not appear, it could be due to changes made to the WaveShaper IP settings. The WaveShaper IP setting can be reset to the default mode with the reset switch. The default mode is "DHCP then Fixed IP".
 - ◆ While the WaveShaper is running, press and hold the reset switch at the back of the instrument for at least **5 seconds**.
 - ◆ Let go of the reset switch and afterwards power cycle the WaveShaper.
 - ◆ The WaveShaper should then be discoverable in the WaveShaper Connect window.

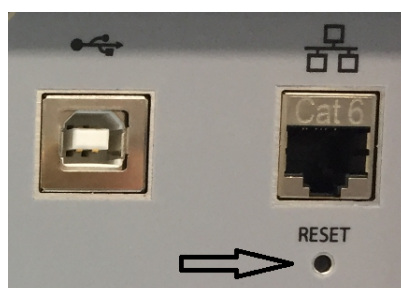

For further detailed technical help, please visit the Finisar KnowledgeBase website.

If there are still connection issues, then please contact us by email: waveshaper@finisar.com

2.5 WaveShaper Mac Address

For both the Module and Benchtop, the MAC addresses of the USB and Ethernet interfaces are printed on the Serial Number Label.

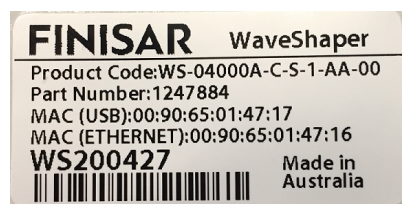

Section 3 Graphical User Interface

3.1 Filter

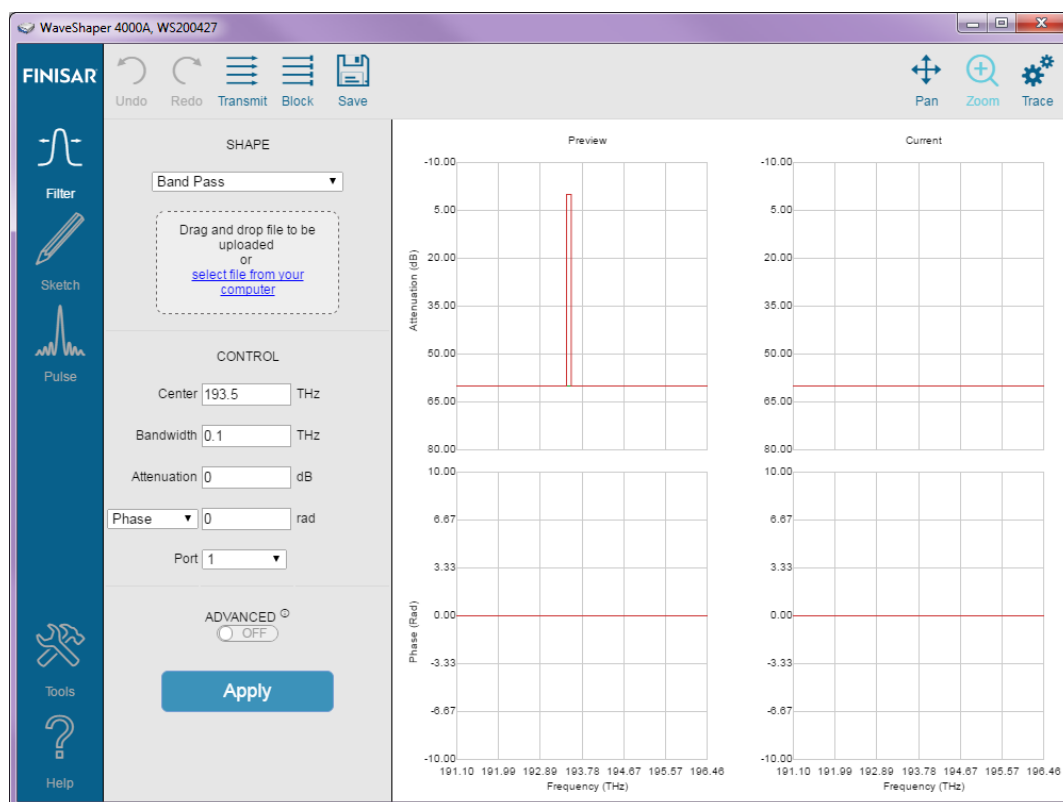

3.2 Shape

Optical Filter Profile

For all Series A WaveShapers except the 100A, a preset optical filter profile can be applied which is defined either by simple internal profiles stored within the WaveShaper (Flat-top Band-pass, Gaussian Band-pass or Band-stop) or from a user-specified filter stored on the users' computer. (For a WaveShaper 100A, only the internally-defined Flat-top and Gaussian Band-pass filter shapes are available).

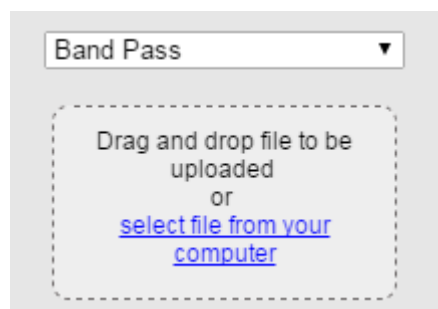

Changing the Optical Filter Profile

When controlling a WaveShaper, the user can select the filter shape from a drop-down list comprising all pre-programmed filters (Bandpass, Gaussian, Bandstop), together with User Configured Filter (UCF) and WaveShaper Preset (WSP) files stored on the user's computer. To upload a new *.UCF or *.WSP file to the WaveShaper, either select it from the drop-down list or drag and drop it to the indicated area on the control panel. In all cases, it is necessary to click "Apply" to upload the new profile.

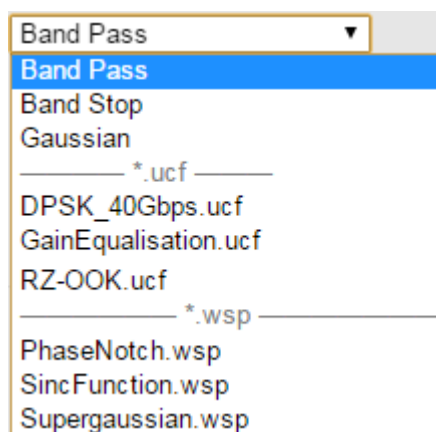

3.3 Control

Center

This allows the user to set the center frequency of the filter and is programmable in 1 GHz steps. The value which can be entered is limited to the operating range of the unit. Center Frequency control is not available if a WSP file is selected.



Bandwidth

This allows the user to change the bandwidth of the filter selected in 1 GHz increments. The display shows the nominal 3 dB bandwidth selected. The change in the bandwidth is symmetric to within ± 2 GHz around the center of the filter. Note: The bandwidth control is accurate for values down to approximately 20 GHz, below this value the bandwidth approaches the instrument's optical transfer function of approximately 10-12 GHz. Bandwidth Control is not available if a *.WSP or *.UCF file is selected.

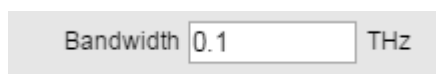

Attenuation

The Attenuation Control provides a power control function for the current filter. Attenuation control is not available for the 100A or if a WSP file is selected.



Port

The Port Selector Control is only available for the 4000A and 16000A range of Series A WaveShapers. Port Control is not available if a WSP file is selected.



4000A

The port selector allows the user to select the port to which the output is directed. The default value after start-up is Port 1.

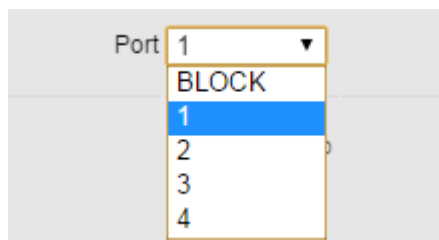

16000A

The 4x16 configuration is the default configuration loaded up when the WaveShaper App is first started. The default values after start-up are Input Port A and Output Port 1. To select any of the other available configurations, use the WaveShaper Configuration option in the Tools tab.

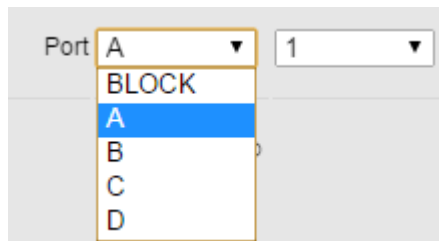

Phase Control

The drop down list box lets the user select how to define one of phase, group delay or dispersion control values for the WaveShaper. Phase control is not available for the WaveShaper 100A or WaveShaper 500A or if a *.wsp file is selected.

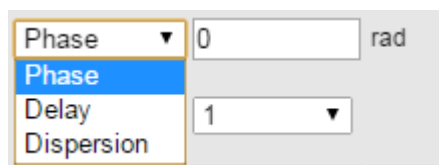

Phase

Allowable range: -2π to 2π rad



Delay

Allowable range: -25 to 25 ps

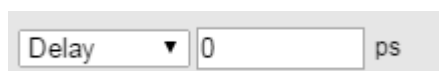

Dispersion

Allowable range: -100 to 100 ps/nm (for a 50 GHz bandpass filter)

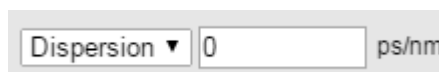

3.4 Graph Control

PAN

Allows you to grab the trace and move it to a different part of the graph. The axes numbers will update automatically. To RESET, use the ZOOM icon and zoom out.



ZOOM

Allows you to zoom in on an area of interest. To Zoom IN, drag with the mouse from top left to bottom right. To Zoom OUT or RESET the graph, drag the mouse from bottom right to top left on the graph. The axes numbers will update automatically.

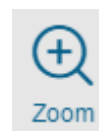

TRACE

Allows you to select and deselect port traces as well as define which graphs are visible in the WaveShaper App window.

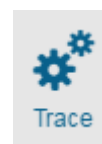

3.5 Advanced

Spectral Range Control

This control allows the user to control the spectral range and, if required, the repeat function, over which a filter function is applied. The Window function is used to limit the applied range of a UCF and also to define the region of the frequency spectrum which is updated when the "Apply" button is pressed. The control allows the user to set the 6 dB window applied to the selected filter in 1 GHz increments from 10 GHz up to the operating range of the unit. The change in the window is symmetric around the center of the filter. Adjustment of the Window is through direct editing in the entry box. **Note:** The Window control is accurate for values down to approximately 20 GHz. Below this value the bandwidth approaches the instrument transfer function of approximately 10 GHz.

ADVANCED [Ⓞ]

ON

Window: THz

Centred at: 192.3 THz

Repeat every: THz

For times

Repeat Function

The repeat function allows the user to specify repeat applications of this filter at a specified frequency gap for a specified number of times (up to the operational limit of the unit). The Window function is defined at 6 dB as this is the value which is required to ensure that the function can be stacked one-against-the-other for use when switching signals using the WaveShaper 4000A or 16000A to emulate a Wavelength Selective Switch. For a mathematical derivation of this, see the White paper entitled "Filter Bandwidth Definition of the WaveShaper S-series Programmable Processor" available on the Finisar website.

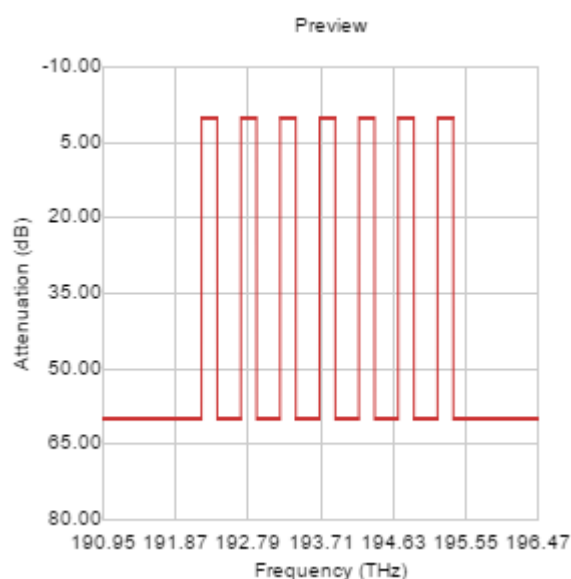

3.6 Sketch

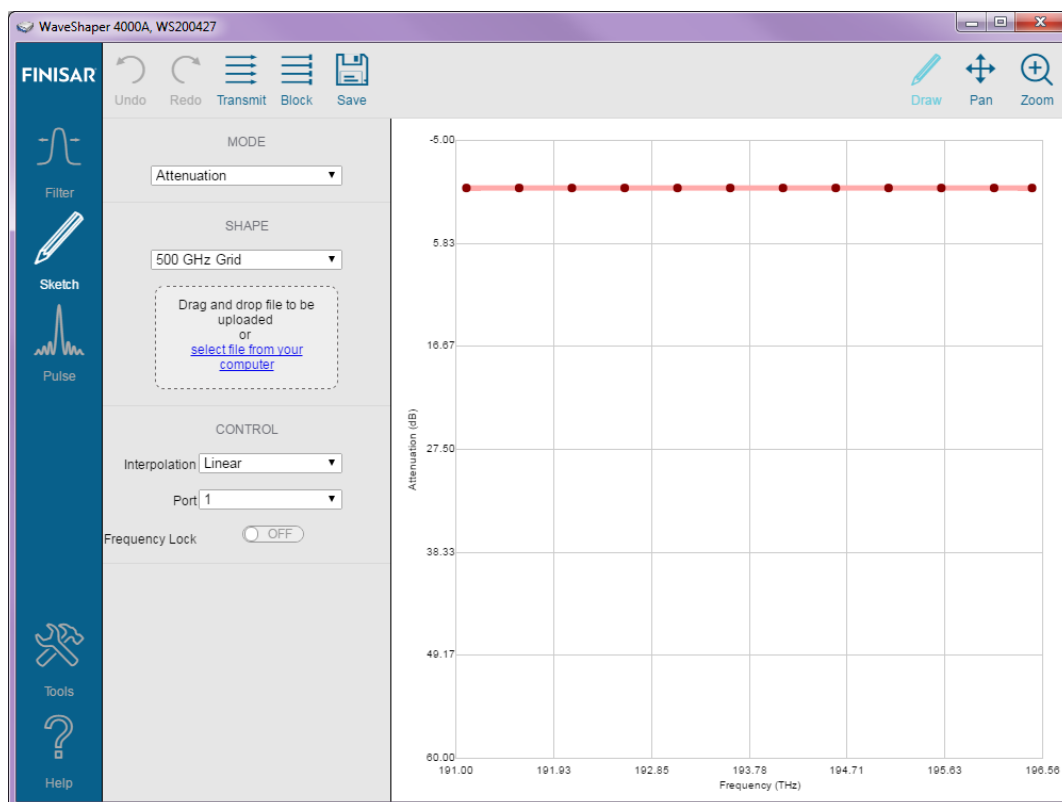

For all Series A WaveShapers except the 100A, the Sketch application provides a powerful and intuitive graphical user interface for controlling the attenuation, phase, group delay or dispersion of a WaveShaper in real time. With a double-click of a mouse, users can create data points in the WaveShaper frequency spectrum and, based on the selection of the interpolation method between the data points, Sketch creates a visual representation of the profile which is loaded into the attached WaveShaper device in real time.

Sketch provides graphical tools to create, drag and drop, single data points and area selected sets of data points. It has selected area zoom in and full view reset capability for the graphical view. The created filters can be saved as Preset Point Data files for future use and exported as WaveShaper Preset (*.wsp) files for later downloading direct to supported WaveShapers.

3.7 Mode

Mode Selection

Select what is to be controlled from a drop-down menu. For the 500A, only the attenuation option is available. When the Phase, Group Delay and Chromatic Dispersion are selected, a second graph will appear below the attenuation sketch graph. A grid can be applied to the second graph for ease of selection.

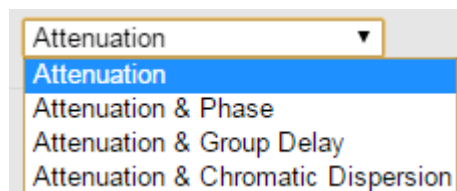

Attenuation and Phase

Allows the adjustment of the phase in the bottom window. The phase sketch points are blue. The allowable range is -2π to 2π radians.

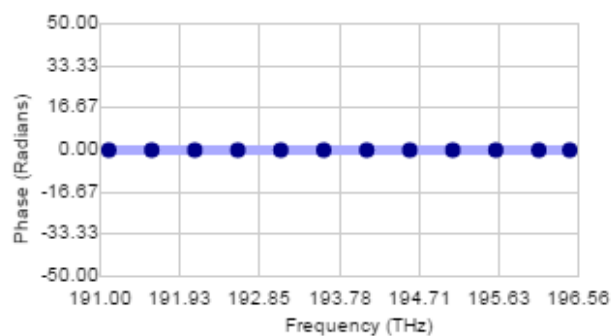

Attenuation and Group Delay

Allows the adjustment of the Group Delay in the bottom window. The phase sketch points are green. The allowable range is -25 to 25 picoseconds.

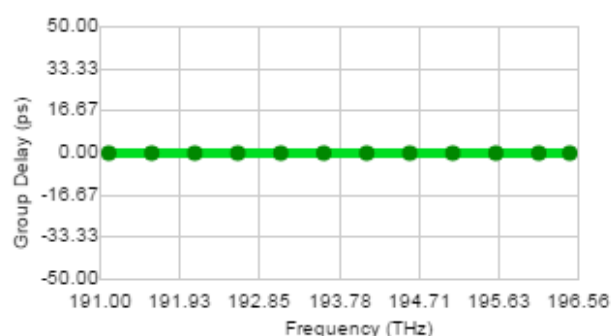

Attenuation and Chromatic Dispersion

Allows the adjustment of the Chromatic Dispersion in the bottom window. The phase sketch points are orange. The allowable range is -100 to 100 ps/nm (for a 50 GHz bandpass filter).

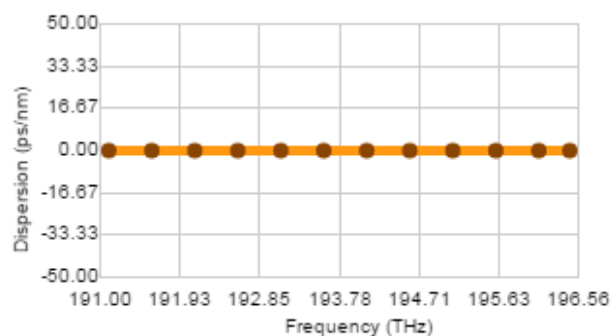

3.8 Shape

Grid Selection

Select an existing sketch grid file from the drop-down list or upload a new file by dragging and dropping it to the indicated area on the control panel. This allows for easy selection of predefined points.

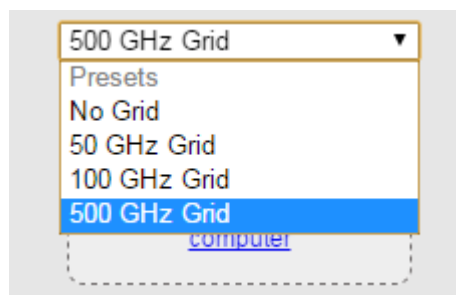

3.9 Control

Interpolation

This allows the user to select the type of interpolation used by the sketch program to generate the WaveShaper filter profile. The interpolation takes place between the data point or points selected and the nearest sketch points on either side.

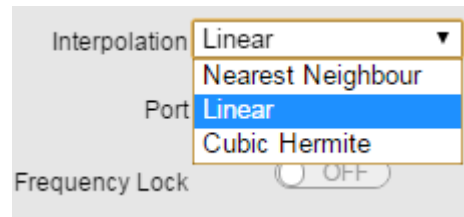

Nearest Neighbour

Produces a square shaped profile when the points are adjusted. The points can be adjusted for both attenuation (vertical direction) or frequency (horizontal direction).

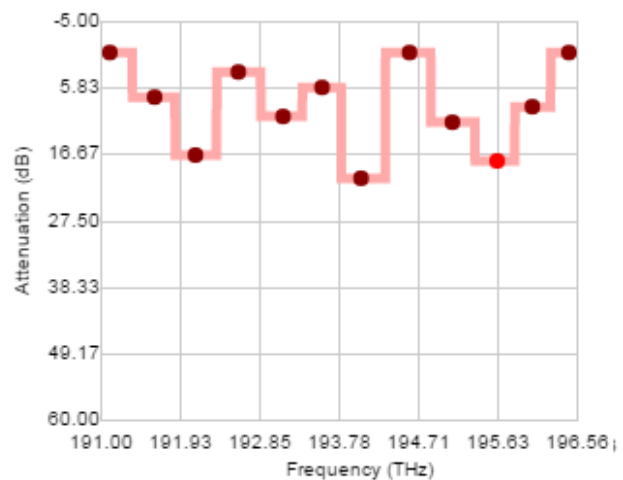

Linear

Produces a triangular shaped profile when the points are adjusted. The points can be adjusted for both attenuation (vertical direction) or frequency (horizontal direction).

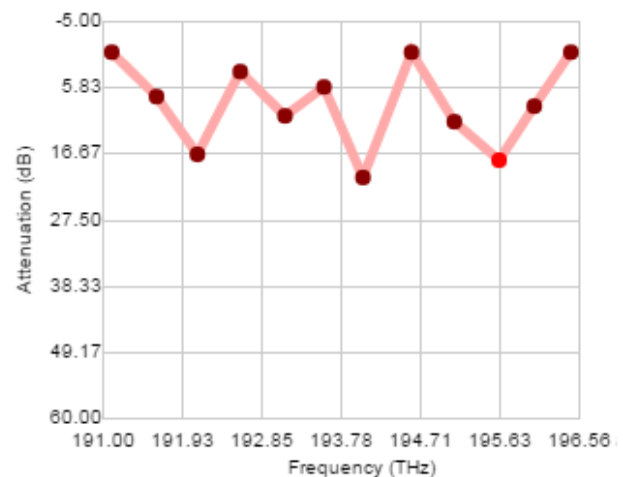

Cubic Hermite

Produces a rounded profile when the points are selected. The points can be adjusted for both attenuation (vertical direction) or frequency (horizontal direction).

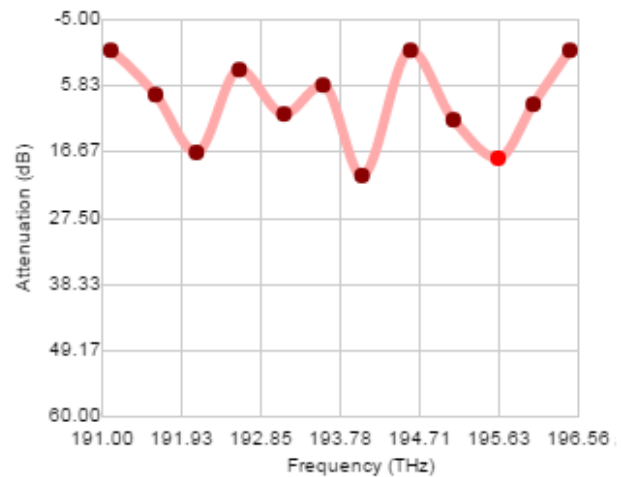

Frequency Lock

When frequency lock is switched on, the frequencies of any existing points are locked and they can only be dragged in the vertical (y-) direction (attenuation adjustment). This allows for the manipulation of the set channels.

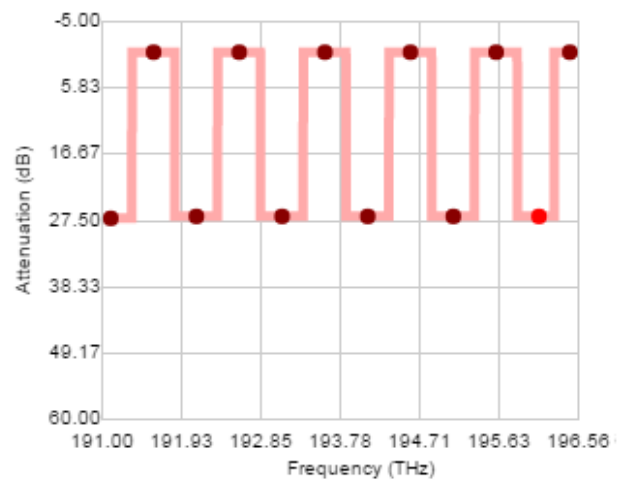

Port

The Port Selector Control is only available for the 4000A and 16000A range of Series A WaveShapers. Port Control is not available if a WSP file is selected. This allows the user to select the port to which the output is directed.



Port Selection 4000A

The default value after start-up is Port 1. The user can use the drop down control to select any of the 4 available output ports.

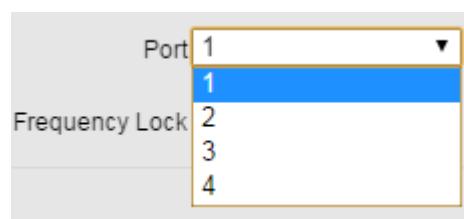

Port Selection 16000A

For the 16000A all ports are indicated by two characters. The first character is the input port and the second is the output port. The default configuration file is 4x16 and the default value for this configuration is A-1. The user can use the drop down control to select any of the 64 available output ports. The port selection list will be different for each configuration and the port list will change depending on the configuration that is currently active.

- ◆ 4x16 configuration, 64 ports, default A-1
- ◆ 1x19 configuration, 19 ports, default A-B
- ◆ 8x12 configuration, 96 ports, default A-5
- ◆ 10x10 configuration, 100 ports, default A-7

To select any of the other available configurations, use the WaveShaper Configuration option in the Tools tab.

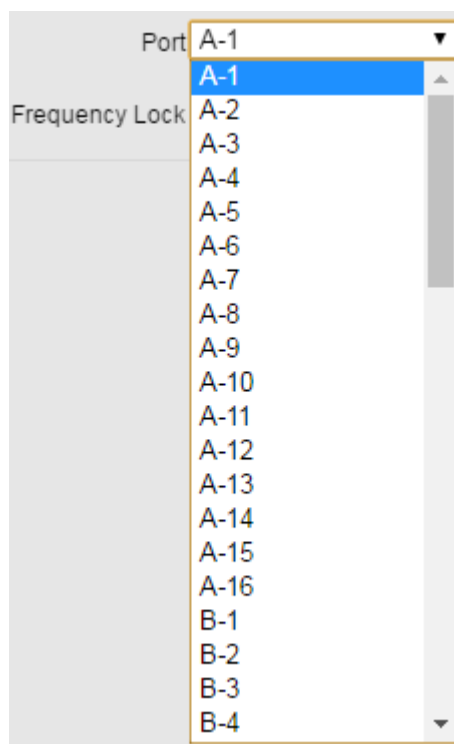

3.10 Graph Control

DRAW

Allows you to directly manipulate points on the sketch trace. See the section on Modifying Points for more details.



PAN

Allows you to grab the trace and move it to a different part of the graph. The axes numbers will update automatically. To RESET, use the ZOOM icon and zoom out.



ZOOM

Allows you to zoom in on an area of interest. To Zoom IN, drag with the mouse from top left to bottom right. To Zoom OUT or RESET the graph, drag the mouse from bottom right to top left on the graph. The axes numbers will update automatically.



3.11 Sketch Manipulation

Selecting Points

Click on a single point to select that point. The point will turn a bright orange colour. By clicking and dragging that point, you can change the shape of the sketched profile. Click anywhere else in the graph area to deselect the point.

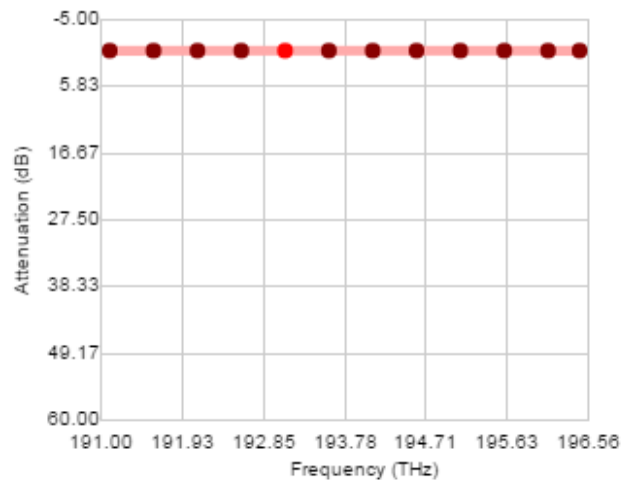

Adding Points

Double click on the sketch graph area to add a point to the sketch profile. This extra data point can be manipulated by selecting and dragging the point around in the graph window.

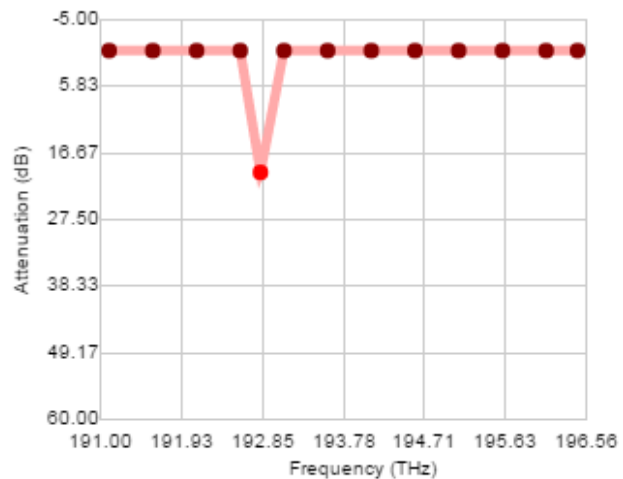

Grouping Points

Click and drag the mouse to select a group of points. The selected points turn a bright orange colour. The group of points can be manipulated by dragging to a different area in the graph. Clicking elsewhere in the graph will deselect those points.

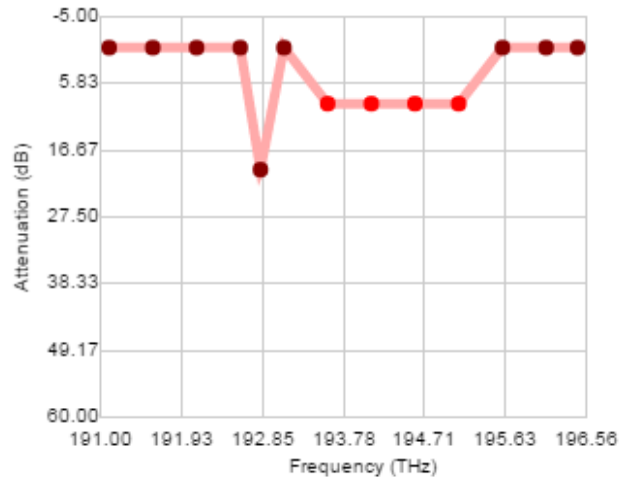

Deleting Points

Select a single point or a group of points. Hitting the delete button will delete the selected point or points.

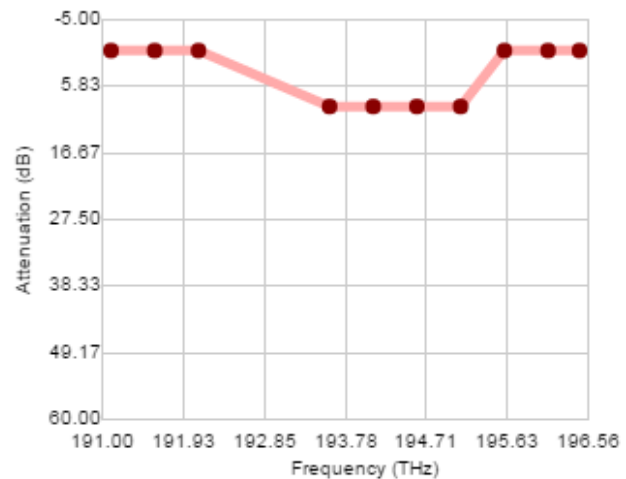

Undo and Redo

The Undo and Redo buttons allow you to go back and forward through a number of changes made to the sketch profile. It will also restore deleted points from the sketch profile.

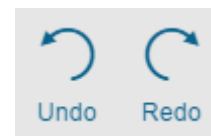

3.12 Pulse Shaping

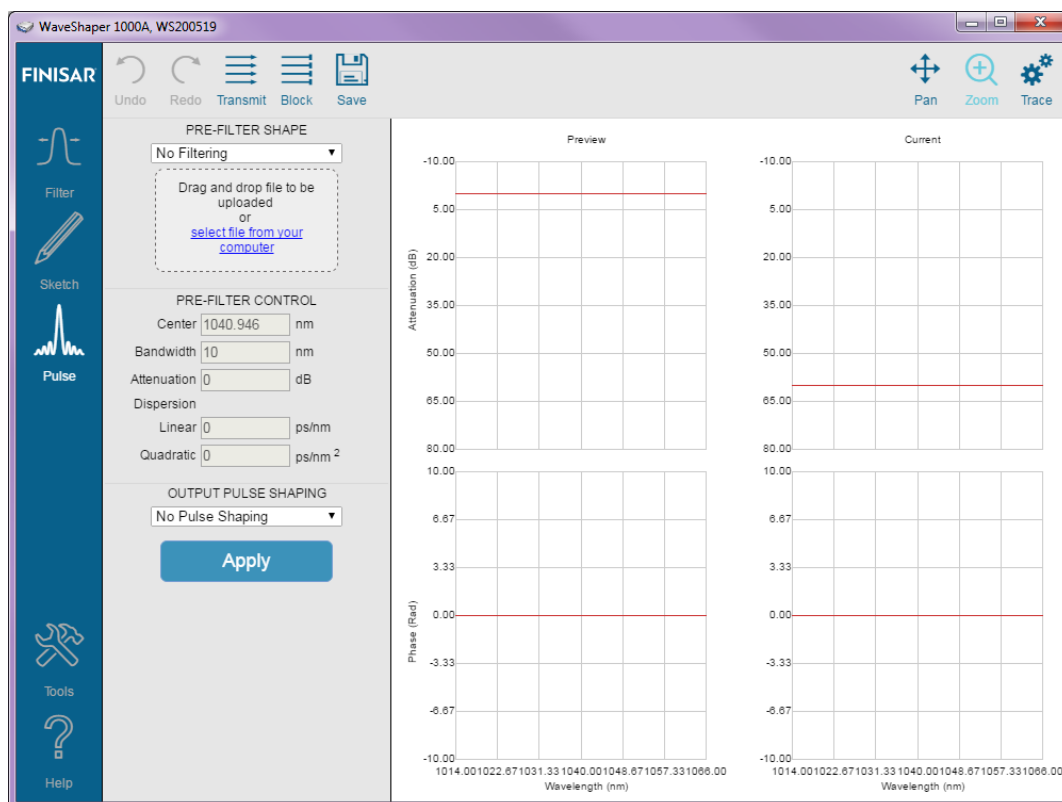

Pulse shaping is a powerful optical technique whereby the frequency-domain of a pulse or sequence of pulses is manipulated in order to alter its properties. The dedicated control page in the WaveShaper App allows precise and easy control of the pulse amplitude and phase to completely define the temporal (or spectral) properties of a laser pulse. The pulse shaping function is available for all versions of the 1000A, 4000A and 16000A WaveShaper instruments.

3.13 Pre-Filter Shape

Available Filters

Defines a basic filtering scheme. Typically, this pre-filtering is used to achieve a transform limited pulse shape. The user can select the filter shape from a drop-down list comprising pre-programmed Bandpass and Gaussian filters as well as the option of having "No Filtering".

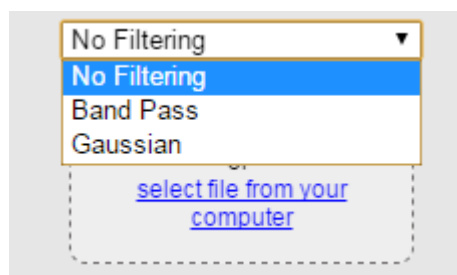

User Filters

In addition to this, User Configured Filter (UCF) and WaveShaper Preset (WSP) files can be uploaded to the WaveShaper. To upload a new *.UCF or *.WSP file to the WaveShaper, either select it from the drop-down list or drag and drop it to the indicated area on the control panel. In all cases, it is necessary to click "Apply" to upload the new profile.

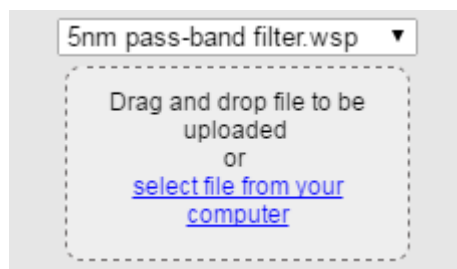

3.14 Pre-Filter Control

Center Frequency

This allows the user to set the center frequency of the filter and is programmable in 1 GHz steps. The value which can be entered is limited to the operating range of the unit. Center Frequency control is not available if a WSP file is loaded.

Center nm

Bandwidth

This allows the user to change the bandwidth of the filter selected in 1 GHz increments. The display shows the nominal 3 dB bandwidth selected. Bandwidth Control is not available if a *.WSP or *.UCF file is loaded.

Bandwidth nm

Attenuation

The Attenuation Control provides a programmable insertion loss for the current filter. Attenuation control is not available if a WSP file is selected.

Attenuation dB

Dispersion

Dispersion can be controlled in two modes: Linear (ps/nm) and Quadratic (ps/nm²).

Dispersion
 Linear ps/nm
 Quadratic ps/nm²

3.15 Output Pulse Shaping

Pulse Selection

Allows the user to select from a number of output pulse shapes. These output pulse shapes will be created in the case where a transform limited pulse has been generated with the "Pre-Filter Shape" function.

No Pulse Shaping ▼
 No Pulse Shaping
 Gaussian
 Flat-top
 Triangle
 Parabolic
 Double

Gaussian Pulse Shaping

The control option for Gaussian Pulse Shaping is the pulse length adjustment. This example has a bandwidth of 10nm and a pulse length of 10ps.

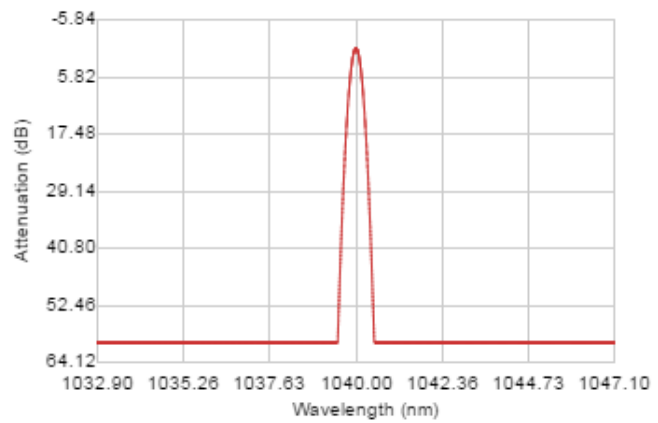

Flat Top Pulse Shaping

The control option for Flat Top Shaping is the pulse length adjustment. This example has a bandwidth of 10nm and a pulse length of 10ps.

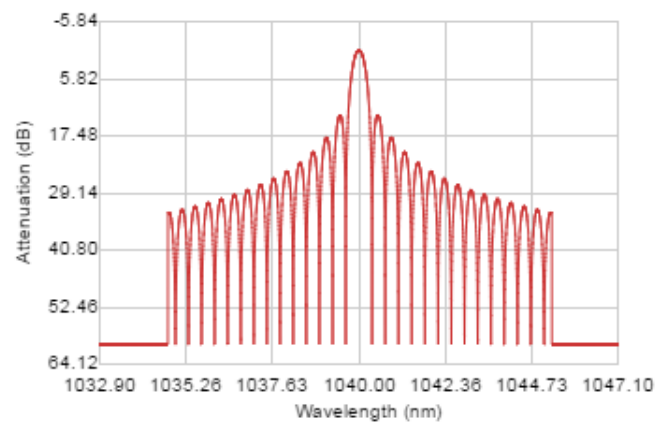

Triangle Pulse Shaping

The control option for Triangle Pulse Shaping is the pulse length adjustment. This example has a bandwidth of 10nm and a pulse length of 10ps.

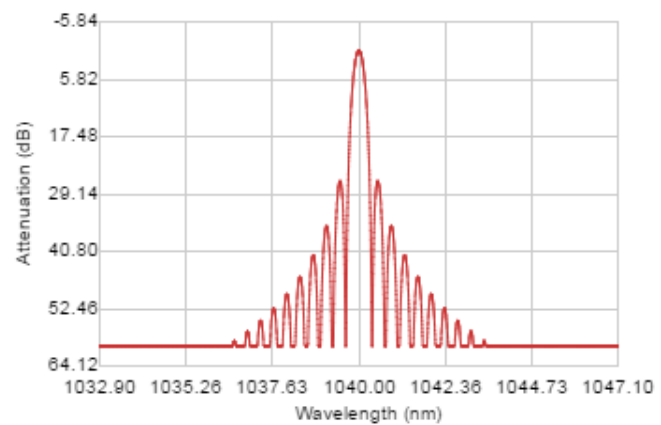

Parabolic Pulse Shaping

The control option for Parabolic Pulse Shaping is the pulse length adjustment. This example has a bandwidth of 10nm and a pulse length of 10ps.

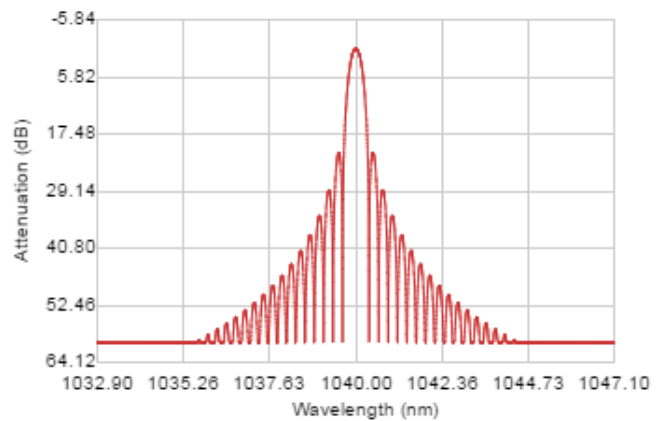

Double Pulse Setting

The control options for Double Pulse Shaping are the pulse length adjustment and the percentage of power to be distributed to each pulse. The power percentage is set by the user. The power percentage and phase are then automatically calculated by the software.

▼
Double

OUTPUT PULSE CONTROL

Delay ps

Power1 %

Power2 %

Efficiency

Double Pulse Shaping

This example has a bandwidth of 10nm and a pulse length of 10ps and a power1 percentage of 50%.

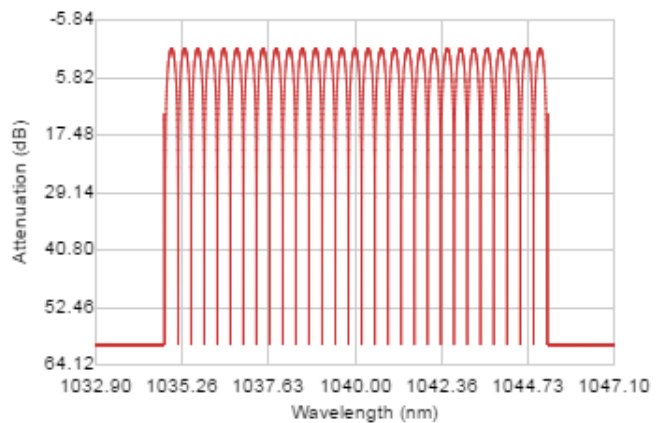

3.16 Graph Control

PAN

Allows you to grab the trace and move it to a different part of the graph. The axes numbers will update automatically. To RESET, use the ZOOM icon and zoom out.



ZOOM

Allows you to zoom in on an area of interest. To Zoom IN, drag with the mouse from top left to bottom right. To Zoom OUT or RESET the graph, drag the mouse from bottom right to top left on the graph. The axes numbers will update automatically.

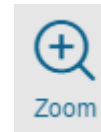

TRACE

Allows you to select and deselect port traces as well as define which graphs are visible in the WaveShaper App window.

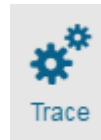

3.17 Tools

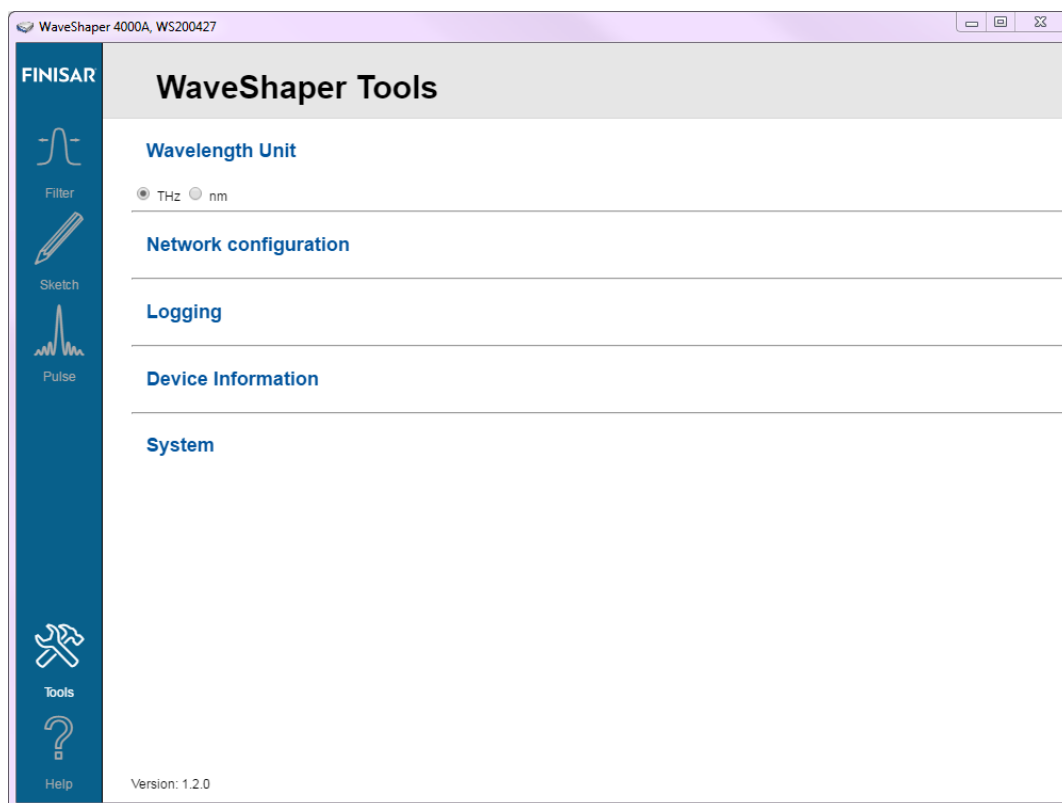

The tools interface is used to make configuration changes to the WaveShaper. It also provides feedback about the device connected as well as provides an interface to obtain system log information.

3.18 Wavelength/Frequency Selection

Wavelength Unit

Use this tool to select units of either Frequency (THz) or Wavelength (nm).

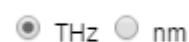

3.19 Network configuration

Current Settings

The Network Configuration will give you the current network IP address settings including the current Fixed IP and Mask addresses. The Gateway address is a router interface connected to the local network that sends packets out of the local network. It is used to allow access to the WaveShaper from a different subnet or Internet. The default setting is blank.

DHCP then Fixed IP
IP: 169.254.6.8 Mask:255.255.0.0

Change

Changing Network Settings

Use this tool to change the network configuration of the WaveShaper. Click on the "Change" button to view the change options. To confirm the options, click on the "Apply" button. To go back without making changes, click on the "Hide" button. If running the WaveShaper App, then you can reboot the WaveShaper using the "Reboot" button in the System options. Otherwise you can power cycle the WaveShaper to apply the changes.

DHCP then Fixed IP
IP: 169.254.6.8 Mask:255.255.0.0

Hide

DHCP then Fixed IP Fixed IP DHCP

IP

Mask

Gateway

Apply

Reset to default

Note: Reboot or power cycle is required to apply changes

DHCP then Fixed IP

DHCP then Fixed IP is the default setting. If the program cannot find an IP address using the DHCP network assignment then it will attempt to connect to the default fixed IP address of 169.254.6.8.

DHCP then Fixed IP Fixed IP DHCP

IP

Mask

Gateway

Apply

Reset to default

Fixed IP

Fixed IP address can be setup so that a permanent IP address is assigned to the WaveShaper. This can be helpful when setting up a test system and the test program can send commands to the same fixed IP address. It is common that after a new IP setting is programmed into the instrument, the WaveShaper will no longer be detectable under the current network connection.

DHCP then Fixed IP Fixed IP DHCP

IP

Mask

Gateway

Apply

Reset to default

DHCP

The DHCP option is used to allow the network configuration to assign the IP to the WaveShaper. This can change depending on the network configuration. For example, by typing in "WS200427.local" directly into the browser address, this will connect to the WaveShaper no matter what IP address has been assigned by the DHCP server.

DHCP then Fixed IP
 Fixed IP
 DHCP

IP
 Mask
 Gateway

Reset Button

If a connection cannot be made to the WaveShaper due to changes made to the IP settings then the IP setting can be reset to the default "DHCP then Fixed IP" mode. To do this, press and hold the reset switch at the back of the WaveShaper for 5 seconds whilst the WaveShaper is powered on. The WaveShaper will then be discoverable in the WaveShaper Connect mode or with the "WS200427.local" IP address in a browser.

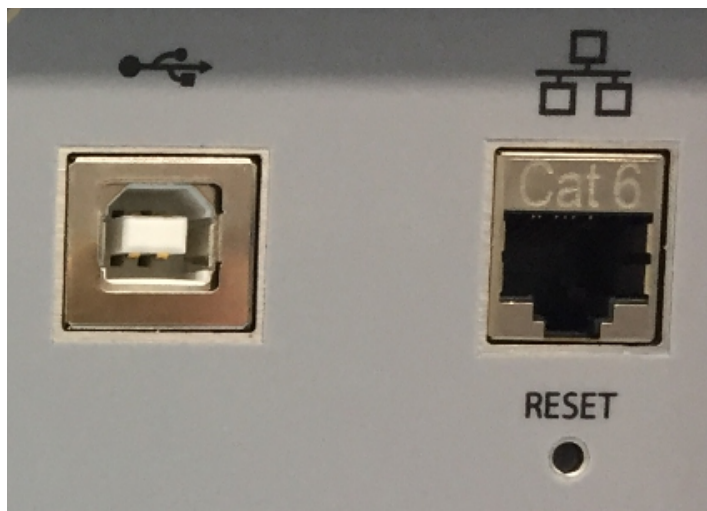

3.20 Logging

Download Log

The logging function is used to download a log file of the WaveShaper activity. This is helpful for troubleshooting purposes. When contacting Finisar with any potential issues, please download this file and send this by email to the Customer Support team.

3.21 Device Information

WaveShaper Details

Used to provide feedback about the device currently connected to the WaveShaper App.

Start Frequency 191.1 THz
 Stop Frequency 196.46 THz
 IP Address 10.118.7.30
 Mac Address 00:90:65:01:47:16
 Serial Number WS200427
 Model 4000A
 Firmware Version 1.2.0

3.22 System

System Update

The purpose of the System update is to allow the WaveShaper App to update the WaveShaper Webserver located on the instrument. The WaveShaper App and WaveShaper Webserver are essentially the same program; the only difference being that the WaveShaper App will show the "System" update menu item. The WaveShaper Webserver which resides on the WaveShaper will not have the System update option available in the tools menu.

.wspkg file

The "Update" button is used to upgrade the firmware of the WaveShaper, in effect upgrading the Webserver program stored on the unit. The firmware file is in the form of a .wspkg file. Any updates to the WaveShaper Firmware will be made available either through the Finisar website or through contact with the WaveShaper Customer Support. A copy of the .wspkg file that shipped with the instrument is available in the local program file folder: C:\Program Files (x86)\Finisar\WaveManager\waveshaperapp\firmware

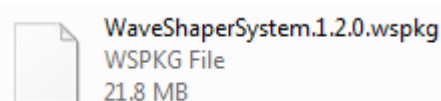
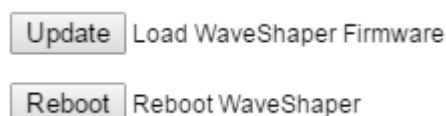

Update Process

To update the firmware, click on the "Update" button then browse to the location where the WaveShaperSystem.wspkg file has been saved. Click on the "Open" button. Once the WaveShaper has been updated, a message will appear, prompting you to "Reboot" the WaveShaper. Note that the power needs to be kept on during the update process otherwise the system can become corrupt and the WaveShaper will not connect.

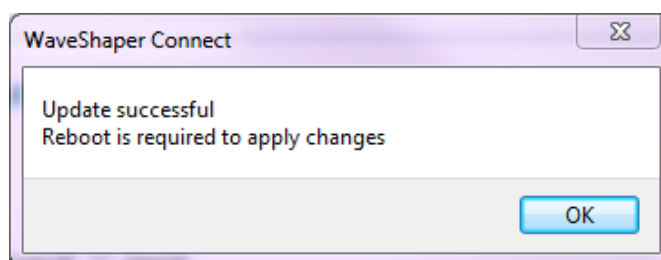

Reboot

Click on the "Reboot" button or power cycle the device and wait until the reboot sequence is complete. During the reboot process, the screen will turn grey, preventing any interaction with the controls. Following a reboot, the updated Webserver program will be uploaded to the WaveShaper when the WaveShaper is next connected to the PC.



3.23 WaveShaper Configuration

Configuration Selection for 16000A Only

This Tools menu option appears just below the Wavelength Unit selection and only appears for the 16000A WaveShaper. Use this tool to select a different configuration file. For a 16000A, the 4x16 configuration is the default. After selecting the desired configuration from the list and clicking on the Apply button, the WaveShaper will reboot automatically and load the new configuration. Note that the Apply button only appears when using the WaveShaper App and not on the WaveShaper Webserver.

- WS200431_4x16
- WS200431_8x12
- WS200431_1x19
- WS200431_10x10

Apply

3.24 Power Splitting

4000A and 16000A WaveShapers

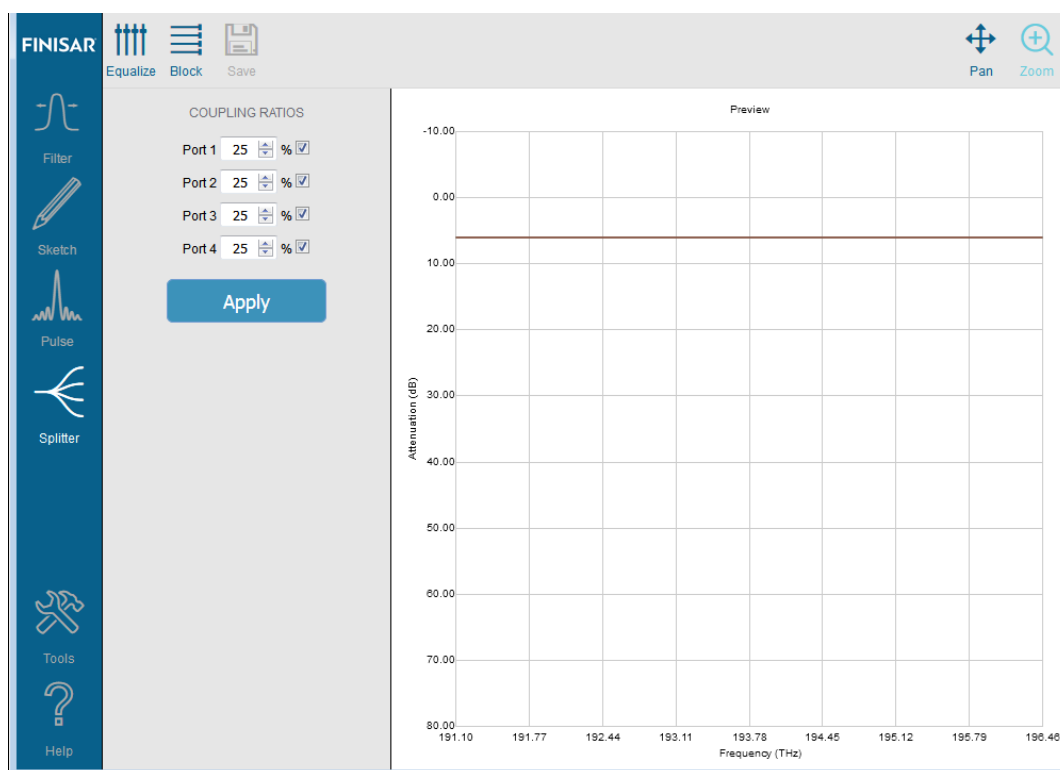

Power splitting allows the user to power share the input spectrum between up to 4 output ports for the 4000A and 16 ports for the 16000A. This functionality is supported both programmatically and through the WaveShaper GUI.

However, it is important to note that, due to the inherent inefficiency of the power splitting algorithm, there is an additional loss associated with power splitting. The extra loss is due to unavoidable diffraction effects which introduces additional attenuation to the WaveShaper depending on the number of active ports.

Number of Active Ports	Power Splitting Efficiency (%)	Additional Attenuation (dB)
1	100%	0
2	75%	1.25
3	70%	1.55
4-5	60%	2.22
6	55%	2.60
7	50%	3.01
8	45%	3.47
9-11	40%	3.98
12-16	35%	4.56

Note: Table showing the extra loss associated with the power splitting algorithm. This loss is in addition to the inherent loss of the WaveShaper.
Example: Splitting to 2 ports gives a total loss of say 4 dB for the WaveShaper + 3 dB for the power splitting to two ports + 1.25 dB additional attenuation due to a power splitting efficiency of 75%. Total loss = 8.25 dB.

3.25 Splitter Controls

Equalize

The "Equalize" button provides a single-click approach to creating an equal splitting ratio between the selected ports. Select the number of ports and the equalize button will calculate and immediately upload the required image to achieve equal parts splitting.

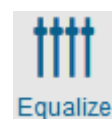

Block

Used to block light going through all selected ports of the WaveShaper



Save Redo/Undo

The save button is disabled – you cannot save profiles created with the GUI. Additionally due to the computationally-intensive nature of the power splitting algorithm, Undo/Redo capability is not supported for power splitting.

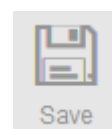

3.26 Coupling Ratios

Settings

Used to define power splitting ratios to all or only some of the available ports on the WaveShaper. Click on the 'Apply' button to upload the required image to the WaveShaper.

- ◆ The minimum per-port power level that can be set is 1%.
- ◆ The sum of the total per-port percentages does not have to equal 100%. This allows attenuation control on a per-port basis.
- ◆ The sum of active port percentages must be $\leq 100\%$. If the sum of active port percentages is larger than 100%, then a warning is generated and the defined splitting cannot be applied to the WaveShaper until the sum is $\leq 100\%$.

COUPLING RATIOS

Port 1	25	%	<input checked="" type="checkbox"/>
Port 2	25	%	<input checked="" type="checkbox"/>
Port 3	25	%	<input checked="" type="checkbox"/>
Port 4	25	%	<input checked="" type="checkbox"/>

Section 4 Defining Optical Filters

4.1 Optical Filter Files

The WaveShaper Series A supports two different input file formats; **.ucf* and **.wsp*.

File Type	File Suffix	Description	Supported By
User Configured Filter	<i>*.ucf</i>	Controls basic WaveShaper Functionality	All models except 100A
Preset	<i>*.wsp</i>	Allows the user to load Preset WaveShaper Configurations	All models except 100A

Note: WaveShaper 500A does not support phase control, but can read **.ucf* and **.wsp* files and apply the amplitude control function therein.

4.2 User Configured Filters (*.ucf)

The ability to load and then easily control user configured filters is key to the operation of the WaveShaper. To this end, the WaveShaper App supports the same *.ucf* file import format used in previous versions of the WaveShaper software.

To ensure data integrity, the software will parse and truncate/interpolate the *.ucf* file to ensure the requested filter shape is calculated to conform to the limits set by the WaveShaper capabilities. The following rules for preparing and interpreting the *.ucf* files therefore apply.

The number of frequency data points must be at least one. The interpolation in the WaveManager software chooses the attenuation and phase values corresponding to the frequency value that is nearest to the respective frequency in the WaveShaper. Hence, if there is only one point defined, all frequencies will be set to the same attenuation and phase values defined by that point. Any WaveShaper frequency outside of the defined frequency range of the input file will be set to the respective edge points of the input file definition, as that will be the nearest neighbour to these frequencies.

For optimal consistency and portability of *.ucf* files between different WaveShapers, it is recommended to specify the profiles down to a resolution of 1 GHz.

File Structure

The format of a **.ucf* file is a tab delimited text file with three columns: Frequency Offset (THz), Attenuation (dB) and Phase (Rad). The file can be generated using a spreadsheet program, such as Microsoft Excel (saving the document as a tab delimited text file). The file extension must set to be **.ucf*.

Frequency

The filter frequency is defined in THz as the detuning (positive and negative) from an arbitrary center frequency. The frequencies do not have to be balanced around the center frequency, but the frequency data set must contain one, and only one, value of zero, which the WaveShaper interprets as the center frequency. The values in the frequency column must also be monotonically increasing. Each frequency data point must have a corresponding value of Attenuation and Phase. If no specific attenuation or phase value is required, values of 0 must be specified at these points.

Attenuation

The calibrated attenuation values available in the WaveShaper hardware are 0 to 30 dB. However, the WaveShaper hardware will control attenuation down to (maximally) 40 dB and also provides a 'Block' state with attenuation of typically >50 dB. To guarantee the portability of filter shapes between WaveShaper units, the **.ucf* attenuation range should be limited to 0-30 dB. The interpretation of the **.ucf* files provides access to the full range of attenuation controls as follows:

Requested Attenuation	*.ucf Interpretation
less than 0 dB	Truncated to 0 dB
0 - 30 dB	Guaranteed accuracy according to the WaveShaper specification
30.1 - 40 dB	WaveShaper attempts to set attenuation to requested value. No guarantee of accuracy
greater than 40 dB	Signal set to 'Block'

Note: Excluding the WaveShaper 100A Tuneable Optical Filter which does not provide attenuation control.

Phase

The phase control range available in the WaveShaper is $0-2\pi$. (Not available for 100A and 500A models.) The User Configured Filter may specify a phase outside of this range; however this will be re-calculated by the WaveShaper software as input phase mod 2π .

Parameter	Units	*.ucf Interpretation
Frequency	THz	Interpolated to fit defined filter bandwidth
Attenuation	dB	Value dependent
Phase	Rad	Modulo 2π

Examples of *.ucf files are provided with the software and should be studied to understand the structure of the file.

Note: There is a degree of inter-linking between the amplitude and phase contouring and varying one will have some effect on the other. In particular, applying large amounts of dispersion to a channel can have a significant impact on the channel amplitude shape. For full details, see M.A.F. Roelens, J. Bolger, G. Baxter, S. Frisken, S. Poole and B.J. Eggleton, "Dispersion Trimming in a Reconfigurable Wavelength Selective Switch", in Journal of Lightwave Technology, vol. 26, p.73, 2008.

Using Microsoft Excel to generate *.ucf files

When using Microsoft Excel to generate a *.ucf file, the following points should be noted.

- ◆ The file should be saved as Text (Tab delimited, *.txt) file and subsequently renamed to have the suffix ".ucf".
- ◆ Before saving as a *.txt file, the format of all columns should be set to 'Number' with at least three (3) decimal places. If the number format is set to less than three decimal places, Excel may misinterpret the data during the translation to a tab delimited file.

4.3 WaveShaper Presets (*.wsp)

Preset files provide a way to fully define the filter/switch profile of a WaveShaper across all Frequencies and Ports. As such it is a very powerful tool to easily configure a WaveShaper to a required complex spectrum.

To ensure data integrity, the WaveShaper software parses the .wsp files to ensure the requested filter shape is calculated to conform to the limits set by the WaveShaper capabilities. The following rules for preparing and interpreting .wsp files therefore apply.

File Structure

The format of a .wsp file is a tab delimited text file with four columns: Absolute Frequency (THz), Attenuation (dB), Phase (Rad) and Port. The file can be generated using a spreadsheet program, such as Microsoft Excel (saving the document as a tab delimited text file). The file extension must be ".wsp" for the file to appear in the File Open dialog box.

Number of Frequency Data Points

Unlike .ucf files, every GHz must be specified for the whole available spectrum in every .wsp file. The first and last points in the file must be within the operating frequency range for the respective WaveShaper model. A partial definition that covers a

continuous range within the valid frequency range is also allowed. To avoid interpolation and rounding problems, it is recommended to check that the frequencies are specified to at least 3 decimal places in the .wsp file.

Frequency

Each frequency data point (specified in absolute terms for *.wsp files) must have a corresponding value of Attenuation, Phase and Port. If no specific attenuation or phase value is required, values of 0 must be specified at these points.

Attenuation

The calibrated attenuation values available in the WaveShaper hardware are 0 to 30 dB. However, the WaveShaper hardware will control attenuation down to (maximally) 40 dB and also provides a 'Block' state with attenuation of typically >50 dB. To guarantee the portability of filter shapes between WaveShaper units, the attenuation range should be limited to 0-30 dB. However, the interpretation of the *.wsp files provides access to the full range of attenuation controls are the same as for *.ucf files.

Requested Attenuation	*.wsp Interpretation
less than 0 dB	Truncated to 0 dB
0 - 30 dB	Guaranteed accuracy according to the WaveShaper specification
30.1 - 40 dB	WaveShaper attempts to set attenuation to requested value. No guarantee of accuracy
greater than 40 dB	Signal set to 'Block'

Note: Excluding the WaveShaper 100A Tuneable Optical Filter which does not provide attenuation control.

Phase

The phase control range available in the WaveShaper is $0-2\pi$. (Not available in the 100A and 500A models, phase must be is set as 0.) The *.wsp file may specify a phase outside of this range; however, this will be re-calculated by the WaveShaper software on interpolation as (phase modulo 2π).

Parameter	Units	*.wsp Interpretation
Frequency	THz	Interpolated to fit defined filter bandwidth
Attenuation	dB	Value dependent
Phase	Rad	Modulo 2π

Port

The port range available depends on the WaveShaper model.

Model	Ports Available
500A, 1000A	The port needs to be either 1 or 0, where 0 corresponds to the block state, and 1 to the only available output port.
4000A	The output port can be set to 0, 1, 2, 3, or 4, where 0 corresponds to the block state.
16000A	The alpha-numeric port combination (e.g. A-1) is referenced by a sequential port number. Consult the tables below to identify the port number for each configuration. Block is again signified by port 0.

4x16 configuration - 64 ports total		
INPUT	OUTPUT	PORT#
A	1	1
...
A	16	16
B	1	17
...
B	16	32
C	1	33
...
C	16	48
D	1	49
...
D	16	64

The port numbers for 4x16 configuration. This is the default configuration for the 16000A. Note that the WaveShaper App version 1.01 only supports the 1x19 configuration. For the other configurations, please upgrade to WaveShaper App 1.2+ or use WaveManager 2.7.4.

1x19 configuration - 19 ports total		
INPUT	OUTPUT	PORT#
A	B	1
A	C	2
A	D	3
A	1	4
A	2	5
...
A	15	18
A	16	19

The port numbers for 1x19 configuration

8x12 configuration - 96 ports total		
INPUT	OUTPUT	PORT#
A	5	1
...
A	16	12
B	5	13
...
B	16	24
C	5	25
...
C	16	36
...
...
4	5	85
...
4	16	96

The port numbers for 8x12 configuration. Note that the WaveShaper App version 1.01 only supports the 1x19 configuration. For the other configurations, please upgrade to WaveShaper App 1.2 or use WaveManager 2.7.4.

10x10 configuration - 100 ports total		
INPUT	OUTPUT	PORT#
A	7	1
...
A	16	10
B	7	11
...
B	16	20
C	7	21
...
C	16	30
...
...
6	7	91
6	16	100

The port numbers for 10x10 configuration. Note that the WaveShaper App version 1.01 only supports the 1x19 configuration. For the other configurations, please upgrade to WaveShaper App 1.2 or use WaveManager 2.7.4.

Section 5 Programming

5.1 RESTful Interface

Web Services

The WaveShaper provides a RESTful style Web service API that enables configuring the device and access to measurement data using HTTP commands from a Web browser or from a software programming language.

Communication with the Series A WaveShapers can be done directly through the browser. Most major languages support sending and receiving http requests via 3rd party tools, although some provide native support.

LANGUAGE	HTTP SUPPORT
LabVIEW	natively via HTTP Client VIs
Python	requests library
MATLAB	webread / webwrite (R2014b onwards)
	urlread2, 3rd party (http://au.mathworks.com/matlabcentral/fileexchange/35693-urlread2)
	urlread (not recommended)
Octave	wget/curl system calls
	urlread (not recommended)
C/C++	libcurl library
Java	Apache HttpClient
Javascript/Node.js	Natively via http.get
C#/VB.NET	System.Net

JSON

The response data is in JSON format. This stands for JavaScript Object Notation which is a lightweight and human readable data format.

JSON is supported by most languages either natively or via 3rd party libraries. An extensive list can be found at <http://www.json.org/>

Some languages have many to choose from, and personal preference is usually the deciding factor.

LANGUAGE	JSON SUPPORT
LabVIEW	natively via JSON VIs
Python	Natively via json library
MATLAB/Octave	JSONlab, 3rd party, (https://au.mathworks.com/matlabcentral/fileexchange/33381-jsonlab--a-toolbox-to-encode-decode-json-files)
C++	Jsoncpp, 3rd party, (https://github.com/open-source-parsers/jsoncpp/wiki)
	Plus several others...
Java	Gson, 3rd party, (https://github.com/google/gson)
	Plus several others...
Javascript/Node.js	Natively via JSON.parse
C#/VB.NET	Several available...

5.2 HTTP API Basics

The WaveShaper uses HTTP GET/POST methods to configure the instrument and upload a filter function. The WaveShaper Web server can be accessed via all available connection methods, with different approaches to defining its IP address.

The most common use case is uploading a filter profile to a WaveShaper. A Web browser can send an HTTP POST request to the WaveShaper Web server, to send the filter profile. For more complex automation, modern programming languages support HTTP requests through common libraries.

Upload Filter

- ◆ **Description:** Upload filter profile to the WaveShaper
- ◆ **HTTP method:** POST
- ◆ **URL:** *http://<_ip_>/wvshaper/loadprofile*
- ◆ **POST Data:** *JSON formatted request includes the following fields.*

JSON FIELD	DESCRIPTION
type	Filter type with one of the following options: <i>wsp, blockall, transmit, bandpass, bandstop, gaussian</i>
wsp	wsp filter definition string only used when type is <i>wsp</i>
port(<i>number</i>)	Port value only used when the type is <i>bandpass, bandstop or gaussian</i>
center(<i>number</i>)	Center frequency in THz only used when the type is <i>bandpass, bandstop or gaussian</i>
bandwidth(<i>number</i>)	Filter bandwidth in THz only used when the type is <i>bandpass, bandstop or gaussian</i>
attn(<i>number</i>)	Attenuation in dB only used when the type is <i>bandpass, bandstop or gaussian</i>

- ◆ **Response:** JSON formatted response includes the following fields.

JSON FIELD	DESCRIPTION
rc(<i>number</i>)	Result code
msg	Result in text format
sno	WaveShaper serial number

Retrieve WaveShaper device information

- ◆ **Description:** Retrieve information about the WaveShaper
- ◆ **HTTP method:** GET
- ◆ **URL:** `http://<_ip_>/wvshaper/devinfo`
- ◆ **Response:** JSON formatted response includes the following fields.

JSON FIELD	DESCRIPTION
model	WaveShaper model
sno	WaveShaper serial number
ver)	Firmware version
startfreq(<i>number</i>)	Start frequency
stopfreq(<i>number</i>)	Stop frequency
ip	Current IP address
portcount(<i>number</i>)	Number of output port(s)
msg	Result in text format

Retrieve currently loaded WaveShaper profile

- ◆ **Description:** Retrieve currently loaded WaveShaper filter profile
- ◆ **HTTP method:** GET
- ◆ **URL:** `http://<_ip_>/wvshaper/getprofile`
- ◆ **Response:** Currently loaded WaveShaper filter profile encoded in WSP formatted string.

5.3 Programming Examples

Overview

The WaveShaper comes with a collection of programming examples for LabVIEW, MATLAB and Python. Each example demonstrates a set of basic functions including: retrieving device information, uploading arbitrary filter shapes, and saving and loading WSP filter files. These examples also demonstrate how HTTP commands and JSON strings work together to control your instrument

Examples

Each example demonstrates a different commonly used WaveShaper function. A complete copy of the code examples may be downloaded from within the help section of the WaveShaper Software. Here is an overview:

Example_UploadPredefinedProfile

Demonstrates how to program the WaveShaper with a predefined filter shape. This example configures the WaveShaper with a *bandpass* filter with a center frequency of 194 THz; bandwidth 1 THz; 0 dB attenuation; and assigned to Port 1. Experiment with changing the filter shape e.g. to a *gaussian*, or *bandstop* filter. The WaveShaper may also be configured to a full *transmit* or a *blockall* state with this mode.

Example_UploadProfile

Demonstrates how to upload an arbitrary filter shape to your WaveShaper. The code example achieves this by generating a WSP string programmatically. It shows how device information can be retrieved from the device via the `/wvshaper/devinfo` API command. Experiment with changing the attenuation or phase functions to see how powerful this feature is.

Example_UploadProfileFromFile

Demonstrates how a pre-existing WSP file may be easily uploaded to the WaveShaper.

WSMethods Function Set

The examples make use of a set of lower-level functions that may be used to meet a wider variety use-cases. Here is an overview:

createWspString

This function is used to combine a set of frequency, attenuation, phase and port arrays into a single WSP string. This string may be directly uploaded to the WaveShaper, or saved to file for later use.

splitWspString

This function is used to parse a WSP string into a set of frequency, attenuation, phase and port arrays. These arrays may then be processed in any way that fits your application.

uploadProfile

This function simplifies the task of uploading arbitrary filter shapes by abstracting away the handling of JSON strings and HTTP commands.

uploadPredefinedProfile

This function simplifies the task of uploading predefined profile by abstracting away the handling of JSON strings and HTTP commands.

5.4 Python Examples

The Python example code below is written for use with Python 3. In addition, the following packages must be installed:

- ◆ numpy
- ◆ requests
- ◆ json

A complete copy of the code examples may be downloaded from within the help section of the WaveShaper Software.

Example_UploadPredefinedProfile.py

```

import requests
import json
from WSMMethods import *

# Define device IP
ip = '169.254.6.8'
# Define profile according to API
profileType = 'bandpass'# blockall, transmit, bandpass, bandstop, gaussian
centerFreq = 194.000    # THz
bandwidth = 1          # THz
attenuation = 0        # dB
port = 1

# Upload predefined profile using above definition
r = uploadPredefinedProfile(ip, profileType, centerFreq, bandwidth, attenuation, port)

```

Example_UploadProfile.py

```

import requests
import json
import numpy as np
from WSMMethods import *

# Define device IP
ip = '169.254.6.8'

# Get device info
result = requests.get('http://' + ip + '/wvshaper/devinfo').json()

# Set frequency variables from device info
s = result['startfreq']
e = result['stopfreq']

# Create data for wsp
wsFreq = np.linspace(s, e, int((e-s)/0.001 + 1))
wsAttn = 50*np.power(np.sin(2*np.pi/0.5*(wsFreq-193)),2)
wsPhase = np.zeros(wsFreq.shape)
wsPort = np.ones(wsFreq.shape)

# Upload profile using created data
r = uploadProfile(ip, wsFreq, wsAttn, wsPhase, wsPort)

```

Example_UploadProfileFromFile.py

```

import requests
import json
import os
from WSMMethods import *

# Define device IP
ip = '169.254.6.8'

# Read the "wspTestFile.wsp" file from the same directory as this .py file
string = open(os.path.join(os.path.dirname(__file__), 'wspTestFile.wsp')).read()
# Run splitWspString() function using the WSP string from the file
wsFreq, wsAttn, wsPhase, wsPort = splitWspString(string)
# Upload profile using split data
r = uploadProfile(ip, wsFreq, wsAttn, wsPhase, wsPort)

```

5.5 MATLAB Examples

The MATLAB example code must be used with MATLAB version R2014b and above in order to support native web read functionality. It is recommended to use MATLAB version R2016b and above in order to support native JSON functionality. The JSONLab 3rd party toolbox may be used for MATLAB versions prior to R2016b.

A complete copy of the code examples may be downloaded from within the help section of the WaveShaper Software.

Example_UploadPredefinedProfile.m

```

addpath('WSMethods')

% Define device IP
ip = '169.254.6.8';

% Define profile according to API
profileType = 'bandpass'; % blockall, transmit, bandpass, bandstop, gaussian
centerFreq = 194.000; % THz
bandwidth = 1; % THz
attenuation = 0; % dB
port = 1;

% Upload predefined profile using above definition
r = uploadPredefinedProfile(ip, profileType, centerFreq, bandwidth, attenuation, port);

```

Example_UploadProfile.m

```

addpath('WSMethods')

% Define device IP
ip = '169.254.6.8';

% GET device info and decode JSON
result = webread(['http://', ip, '/wvshaper/devinfo']);
result = jsondecoder(result);

% Set frequency variables from device info
s = result.startfreq;
e = result.stopfreq;

% Create data for wsp
wsFreq = linspace(s, e, (e-s)/0.001 + 1);
wsAttn = 50*sin(2*pi/0.5*(wsFreq-193)).^2;
wsPhase = zeros(size(wsFreq));
wsPort = ones(size(wsFreq));

% Upload profile using created data
r = uploadProfile(ip, wsFreq, wsAttn, wsPhase, wsPort);

```

Example_UploadProfileFromFile.m

```

addpath('WSMethods')

% Define device IP
ip = '169.254.6.8';

% Open the "wspTestFile.wsp" file from the same directory as this file
string = fileread('wspTestFile.wsp');

% Run splitWspString() function using the WSP string from the file
[wsFreq, wsAttn, wsPhase, wsPort] = splitWspString(string);

% Upload profile using split data
r = uploadProfile(ip, wsFreq, wsAttn, wsPhase, wsPort);

```

5.6 LabVIEW Examples

The LabVIEW example code has been saved for LabVIEW 2015, and is not compatible with previous versions.

A complete copy of the code examples may be downloaded from within the help section of the WaveShaper Software.

Example_UploadPredefinedProfile.vi

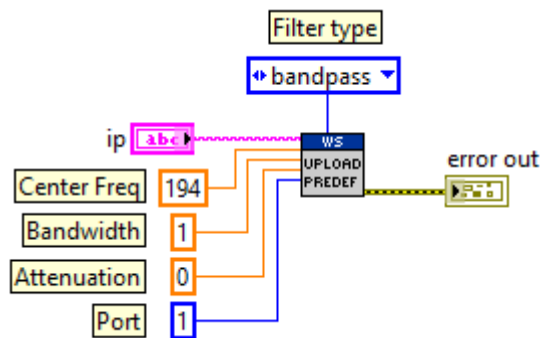

Example_UploadProfile.vi

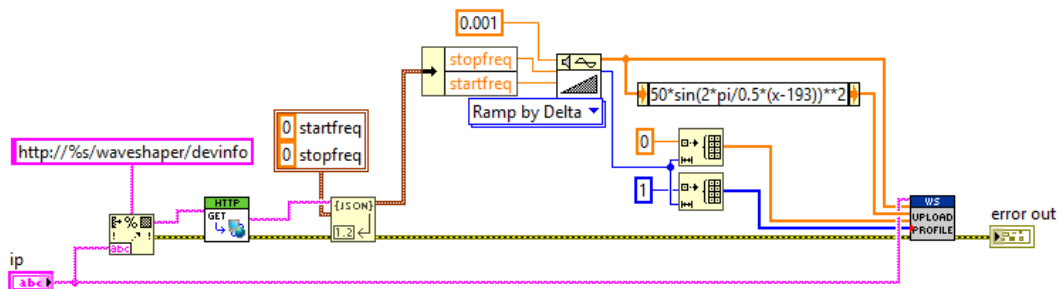

Example_UploadProfileFromFile.vi

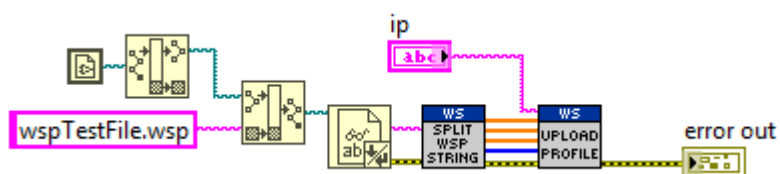

5.7 Power Splitting Programming

The power splitting function can be invoked programmatically using the following "Post" command:

URL: *http://<_ip_>/wvshaper/loadsplitter*

Post Body:

```
{
  "port1" : P1,
  "port2" : P2,
  "port3" : P3,
  "port4" : P4
}
```

where P_n is the power expressed as a normalized proportion of the total power.

Examples

4-way splitter with 20% of the power in Port 1, 20% in Port 2, 40% in Port 3 and 20% in Port 4:

URL: *http://<_ip_>/wvshaper/loadsplitter*

Post Body:

```
{
  "port1" : 0.2,
  "port2" : 0.2,
  "port3" : 0.4,
  "port4" : 0.2
}
```

2-port coupler on ports 2 and 3 with equal splitting between the two coupler outputs:

URL: *http://<_ip_>/wvshaper/loadsplitter*

Post Body:

```
{
  "port1" : 0,
  "port2" : 0.5,
  "port3" : 0.5,
  "port4" : 0
}
```

4-way equal-power splitter with an additional 3dB of attenuation programmed in:

URL: *http://<_ip_>/wvshaper/loadsplitter*

Post Body:

```
{
  "port1" : 0.125,
  "port2" : 0.125,
  "port3" : 0.125,
  "port4" : 0.125
}
```

Return messages

In all cases, a successful Post command will return the following:

```
{
  "msg" : "OK",
  "rc" : 0
}
```

It is the user's responsibility to ensure that the sum of the normalized port power must be ≤ 1 . The WaveShaper performance is not defined for values >1 . If the sum of the normalized port power is >1 , then the following error message will be returned:

```
{
  "msg" : "OK",
  "rc" : 0
}
```

Care should be taken to ensure that the formatting of the command is correct. An incorrectly formatted command (e.g. missing the leading "0" in a value for Pn) will generate the following error message:

```
{
  "rc" : -1,
  "msg" : "error:invalid json format"
}
```

Section 6 Specifications

6.1 Optical Specifications

This table gives a summary of the optical specifications for the entire WaveShaper Series 'A' range

MODEL	SPECIFICATION	100A	500A	1000A/4000A	16000A	1000A/SP ¹	1000A/L,4000A/L	1000A/X,4000A/X	
Optical Ports	Port Configurations	1x1	1x1 (1000A) 1x1 (4000A)	1x19, 4x168x12, 10x10	1x1	1x1 (1000A) 1x1 (4000A)			
Filter Control	Operating Frequency Range	191.1 THz to 196.46 THz (1526.0 nm to 1568.7 nm)			191.250 THz to 196.275 THz (1527.4 nm to 1567.5 nm)	186.20 THz to 191.05 THz (1569.2 nm to 1610.0 nm)	187.275 THz to 196.275 THz (1527.4 nm to 1600.8 nm)		
	Filter Bandwidth	10 GHz to 1 THz (0.08 nm to 8 nm)	10 GHz to 5.36 THz (0.08 nm to 42.7 nm)		10 GHz to 5 THz (0.08 nm to 40 nm)	10 GHz to 4.85 THz (0.08 nm to 40.8 nm)	20 GHz to 9 THz (0.016 nm to 73.4 nm)		
	Filter Shaper	Bandpass	Gaussian	Arbitrary					
	Filter Setting Resolution	±1 GHz (±8 pm)							
	Filter Setting Accuracy	±2.5 GHz (±8 pm)						±5 GHz	
	Bandwidth Setting Resolution	±1 GHz (±8 pm)							
	Bandwidth Setting Accuracy	±5 GHz (±40 pm)						±10 GHz	
	Bandwidth Setting Repeatability	±2.5 GHz (±20 pm)						±5 GHz	
	Group Delay Control Range	n/a	-25 ps to +25 ps					-15 ps to +15 ps	
	Attenuation Control Range	n/a	0 to 35 dB						
	Attenuation Setting Resolution	n/a	0.01 dB	0.1 dB	0.01 dB				
	Attenuation Setting Accuracy	n/a	±1.0 dB from 0 to 10 dB, ±10 % from 10 to 30 dB						
	Settling Time	< 500 ms							
Loss and Dispersion	Insertion Loss	< 5 dB						< 6.5 dB	
	Insertion Loss Non-Uniformity	0.7 dB			0.7 dB ²		1 dB		
	Polarization Dependent Loss (PDL)	0.4 dB		n/a		0.4 dB		0.8 dB	
	Differential Group Delay (DGD)	< 0.5 ps			n/a		< 0.5 ps		
	Return Loss	> 25 dB							
Optical Power	Max. Total Input Optical Power	> 25 dB							
	Max. Optical Power per 50GHz Channel	+ 27 dBm							
Mechanical	Connector Interface	FC/APC	FC/UPC	FC/APC	LC/APC	FC/APC			

Note 1: Measured on signal in slow axis. Note 2: Specification is valid over the frequency range of 187.0 to 191.0 THz. From 186.35 to 187.0 THz the insertion loss non-uniformity is < 1.0 dB max.

Warm-Up Time

The device will meet all specifications following a warm-up period of 10 minutes from a temperature within the normal operating temperature range.

6.2 Electrical Specifications

Module Power Supply

DESCRIPTION/PARAMETER	UNIT	MIN	TYPICAL	MAX	NOTES
Power Consumption	W		19	50	Typical at 25°C after warm-up period, Maximum power consumption occurs during initial stages of warm-up period
Power Supply	V	4.75	5.00	5.25	Measured at Phoenix Connector

External Interfaces to Module

DESCRIPTION	INTERFACE	NOTES
Ethernet Connector	RJ-45	
Power Connector	Phoenix Plug	Phoenix connector supplied with module
USB Connector	Mini USB 2.0	
Reset Pins	Jumper	

Note: Due to the supply wire resistance, the voltage can drop significantly between the power source and the terminal. The supply wire gauge should be chosen to be able to deliver up to 10 A.

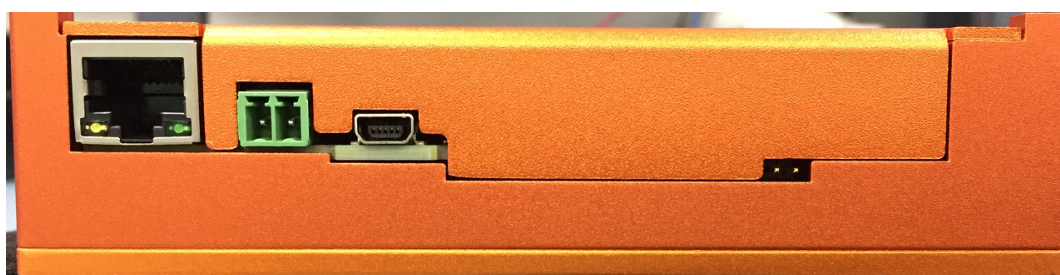

Rear view of the Series A module showing the Ethernet, USB, power supply and reset pins

Benchtop Power Supply

DESCRIPTION/PARAMETER	UNIT	MIN	TYPICAL	MAX	NOTES
Power Consumption	W		20	50	Typical at 25°C after warm-up period, Maximum power consumption occurs during initial stages of warm-up period
Power Supply Voltage (AC)	V	100		240	
Power Supply Frequency	Hz	50		60	

External Interfaces to Benchtop

DESCRIPTION	INTERFACE
Power Connector	IEC
USB Connector	USB 2.0, Type B
Ethernet Connector	RJ-45



Rear view of the Series A benchtop showing the power supply, fan, USB, Ethernet, reset button and serial number.

6.3 Environmental Conditions

Storage Conditions

The WaveShaper should be stored in appropriate dry, temperature controlled conditions to prevent damage to the equipment. Exceeding the ranges defined in the table may result in permanent damage to the equipment.

Absolute Maximum Ratings

CONDITION / PARAMETER	UNIT	MIN	MAX	NOTES
Storage Temperature	°C	-20	+70	
Storage Humidity	%	10	90	Non-condensing
Case operating temperature	°C	15	55	Module Only
ESD	kV		16	Class N per HBM, meets IEC 61000-4-2 level 4

Exceeding the ranges defined here may result in permanent damage to the unit.

Normal Operating Conditions

CONDITION / PARAMETER	UNIT	MIN	MAX	NOTES
Operating Temperature (module)	°C	15	55	Temperature of case with airflow across top of unit. Min flow rate = 1m/sec.
Operating Temperature (benchtop)	°C	15	35	Air temperature measured at input to vents on base of unit
Humidity	%	10	90	Non-condensing

The device will operate within specification provided these operating conditions are met.

