

# SuperK FIANIUM

Pulsed white light fiber laser



# Easy-to-operate white light source

Ideal for bioimaging and characterization of nanomaterials

Built on the World's best-selling supercontinuum laser, the SuperK EXTREME, the SuperK FIANIUM has upgraded electronics and new fiber technology giving you improved performance and reliability. And now it is even easier to use.

The lasers deliver high brightness diffraction-limited light in the entire 400-2400 nm range. Add one of our filter solutions to convert it into an ultra-tunable laser.



## SuperK FIANIUM

---

### Applications

Microscopy

Fluorescence

Lifetime Imaging

Optical Coherence Tomography

Spectroscopy

White light interferometry

Hyperspectral imaging

Plasmonics & meta materials

# Ease of use

## The future-proof choice for innovators

As a scientist, you may not know what you need tomorrow. Address the unexpected with the highly versatile SuperK FIANIUM. The modular design makes it easy to upgrade features and performance to ensure that you are always prepared for the future.

## Wide spectral coverage and high brightness

Our SuperK supercontinuum sources deliver a wide spectral output covering hundreds of nanometers while keeping the high brightness and mode quality known from single line lasers.

## A maintenance-free lifetime of thousands of hours

The SuperK series is based on NKT Photonics' world-renowned Crystal Fibre technology that has reliably delivered supercontinuum to all fields for over 15 years. Our lasers are fully fiber monolithic which ensures excellent reliability and a lifetime of thousands of hours - as well as maintenance-free and alignment-free operation. For scientific applications, we offer a 2-year warranty.

## Easy to operate

Operating the SuperK FIANIUM is easy for users from any discipline, no laser expertise is needed. The SuperK CONTROL graphical user interface on your PC gives intuitive control of all functions in the laser.

The system is fully modular, allowing easy operation and service. Accessory modules can be added without configuration—all plug & play. Change a large number of parameters on-the-fly, without powering down the system.

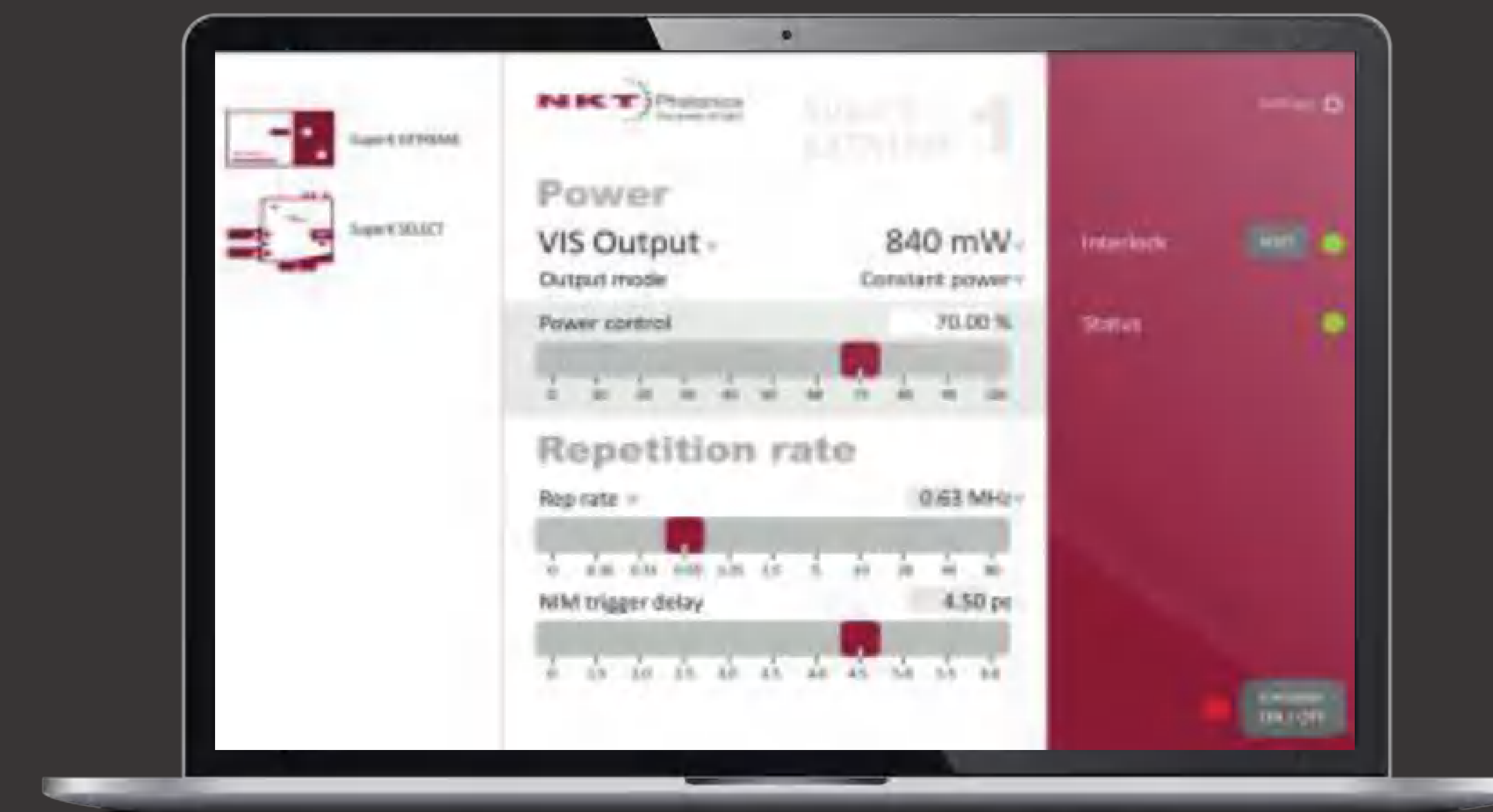

# SuperK FIANIUM

## NKT Photonics CONTROL

Like other NKT Photonics lasers, the SuperK EVO can be controlled by our intuitive CONTROL software that gives easy access to all laser functions. The software automatically detects all units attached to the computer.

You can control the source and any filtering accessories from CONTROL. It is easy to use and supports touch input as well as traditional mouse + keyboard control.

# Options

## Variable Repetition Rate (Pulse Picker)

The pulse picker option allows the repetition rate of the SuperK FIANIUM to be easily changed on-the-fly while the system is running at full output.

Repetition rates of 0.15-78 MHz are available as standard, giving the user ultimate choice for lifetime measurement applications such as FLIM.

The electrical output trigger signal can be delayed up to 9.2 ns in steps of 15 ps. This enables trigger delay optimization without the need for a delay box.



<b>Repetition rate (fixed) <sup>1</sup></b>	78 MHz
<b>Variable repetition rate (optional) <sup>1</sup></b>	0.15 - 78 MHz
<b>Pulse suppression ratio</b>	> 1:10,000
<b>Repetition rate switching time</b>	< 1 s
<b>Trigger out signals</b>	NIM, logic, analogue
<b>Trigger signal jitter</b>	< 20 ps
<b>Adjustable trigger delay <sup>2</sup></b>	Up to 9.2 ns
<b>Adjustable trigger delay resolution</b>	15 ps

<sup>1</sup> Can be modified upon request. <sup>2</sup> The electrical output trigger signal can be delayed up to 9.2 ns in steps of 15 ps.

# SuperK FIANIUM

## Support and warranty

Before shipping, all our SuperK lasers undergo an extensive burn-in to ensure performance and conformity to specifications. Our systems boast over 10,000 hours of continuous lifetime and underlines the high reliability of our NKT Photonics Crystal Fiber technology.

## Lifetime and service

The solid-state, all-fiber architecture ensures a stable 24/7 operation and a maintenance-free lifetime of thousands of hours. Intended for industrial use, its rugged and compact design make it easy to mount and handle.

# Spectral power density

**SuperK**  
FIANIUM

SuperK FIANIUM typical output spectrum

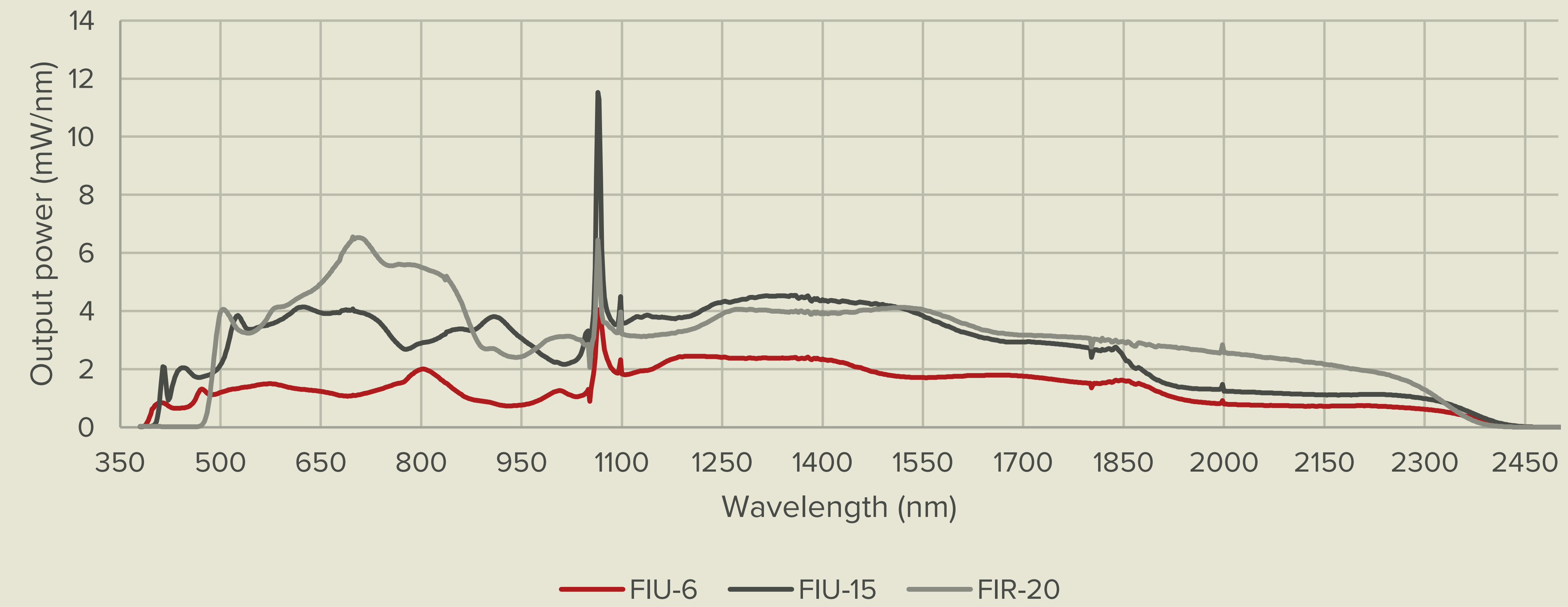

SuperK FIANIUM spectral coverage

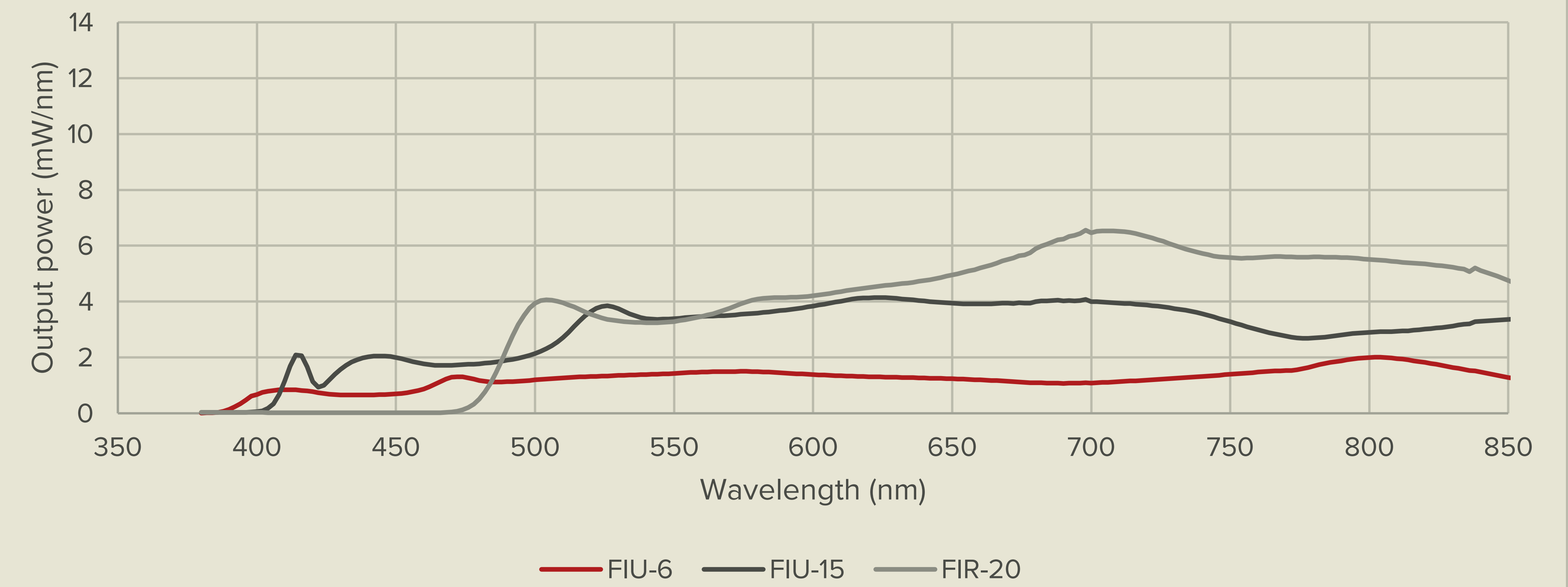

# Collimator

**SuperK**  
FIANIUM

The optical output of the laser is a collimator at the end of an armored fiber cable.

A collimated beam exits the collimator from a steel sleeve connector designed for insertion into a receptacle of a target optical device such as, for example, a SuperK accessory, holder, or specifically engineered optical device.

Once inserted, the substantial construction of the collimator maintains the output beam alignment.

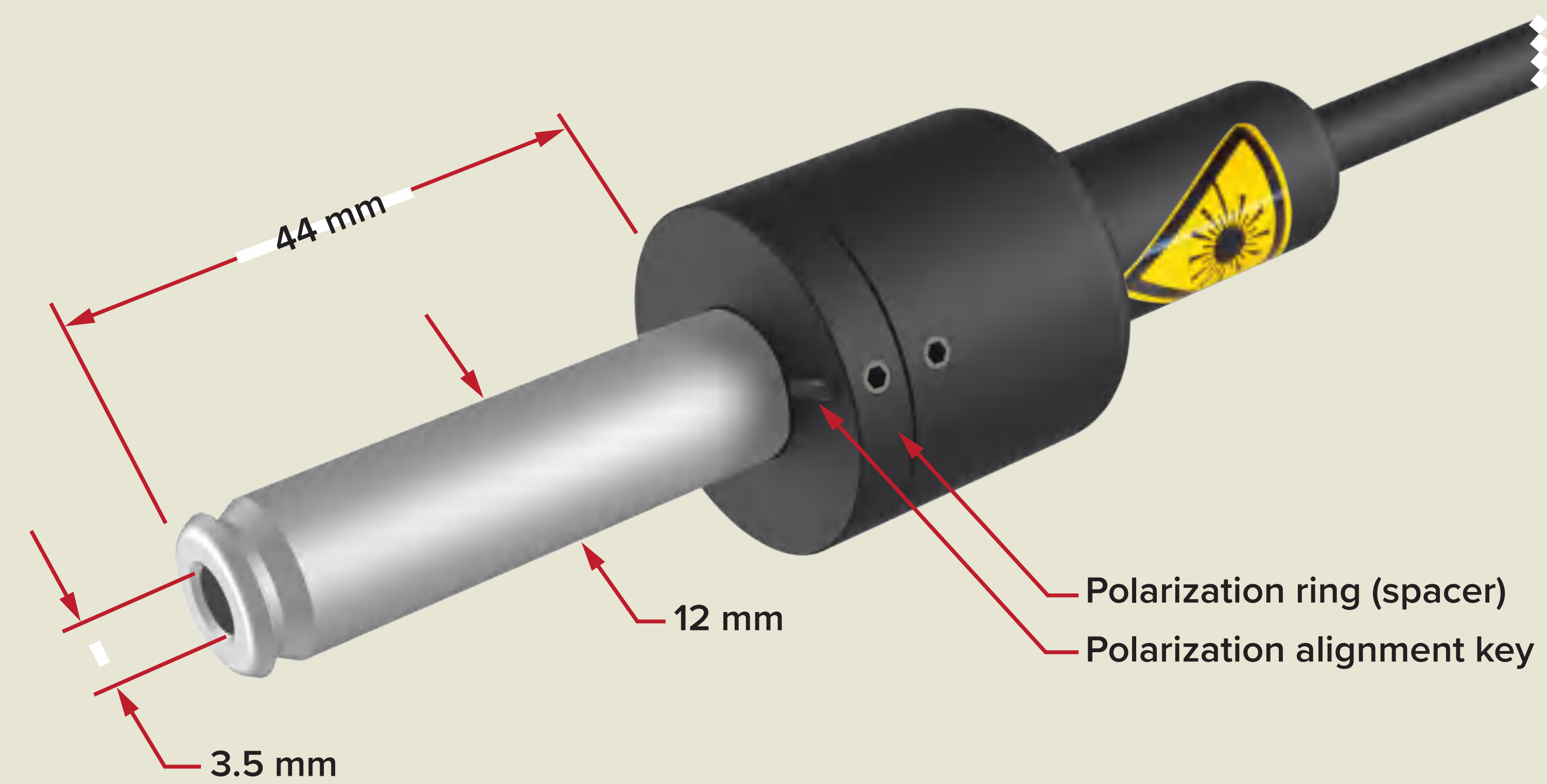

# Specifications

**SuperK**  
FIANIUM

## Optical

Model	FIU-6	FIU-15	FIR-20
Repetition rate [MHz]	78	78	78
Variable repetition rate [MHz] (optional)	0.15 - 78	0.15 - 78	0.15 - 78
Spectral power density [mW/nm]	0.6 @ 450 nm 1.3 @ 532 nm 1.2 @ 650 nm 1.8 @ 780 nm 2.0 @ 800 nm	2.0 @ 450 nm 4.0 @ 532 nm 4.0 @ 650 nm 2.5 @ 780 nm 2.8 @ 800 nm	N.A 3.2 @ 532 nm 4.7 @ 650 nm 5.4 @ 780 nm 5.2 @ 800 nm
Total power [W]	≈ 2.2	≈ 5.5	≈ 6.5
Visible power (350-850 nm) [W]	≈ 0.6	≈ 1.5	≈ 2.0
Power stability [%] <sup>1</sup>	± 0.5	± 0.5	± 0.5
Cut-in wavelength (>0.1mW/nm) [nm]	400	415	475
Polarization	Random	Random	Random
Beam quality	M2 < 1.1	M2 < 1.1 <sup>2</sup>	M2 < 1.1
Beam diameter (collimated version) [mm]		≈ 1 @ 532 nm ≈ 2 @ 1100 nm ≈ 3 @ 2000 nm	
Beam pointing accuracy [mrad] <sup>3</sup>		< 1	

<sup>1</sup> Average of a 2-hour measurement of the visible spectrum.  
The note stability per filtered line may vary with wavelengths.

<sup>2</sup> For >450 nm.

<sup>3</sup> Measured relative to the mechanical axis running through the center of the collimator.

# Specifications

## Electrical/Mechanical

<b>Computer interface</b>	USB 2.0/RS-232/Ethernet
<b>Operation voltage [Hz]</b>	100-240 VAC 50/60
<b>Power consumption [W]</b>	< 100 (<120 with pulse picker)
<b>Door interlock connector <sup>1</sup></b>	2-pin LEMO
<b>External bus interface <sup>2</sup></b>	16-pin sub-D
<b>System cooling</b>	Air-cooled
<b>Length of output fiber [m]</b>	1.5
<b>Operation temperature [°C]</b>	18 - 30
<b>Storage temperature [°C]</b>	-10 - 55
<b>Dimensions (WxHxL) [mm]</b>	440 x 251 x 400
<b>Weight [kg]</b>	18 (19 with pulse picker)

<sup>1</sup> The SuperK FIANIUM is a Class 4 laser and is required to be connected to a door interlock/circuit

<sup>2</sup> External communication and power supply port for accessories

## SuperK FIANIUM

---

### Software Development Kit (SDK)

The free software development kit (SDK) enables control of the SuperK FIANIUM laser using third party software and hardware.

The SDK contains a full description of the communication protocols as well as LabView drivers and C++/C# source code.



# Technical Drawings

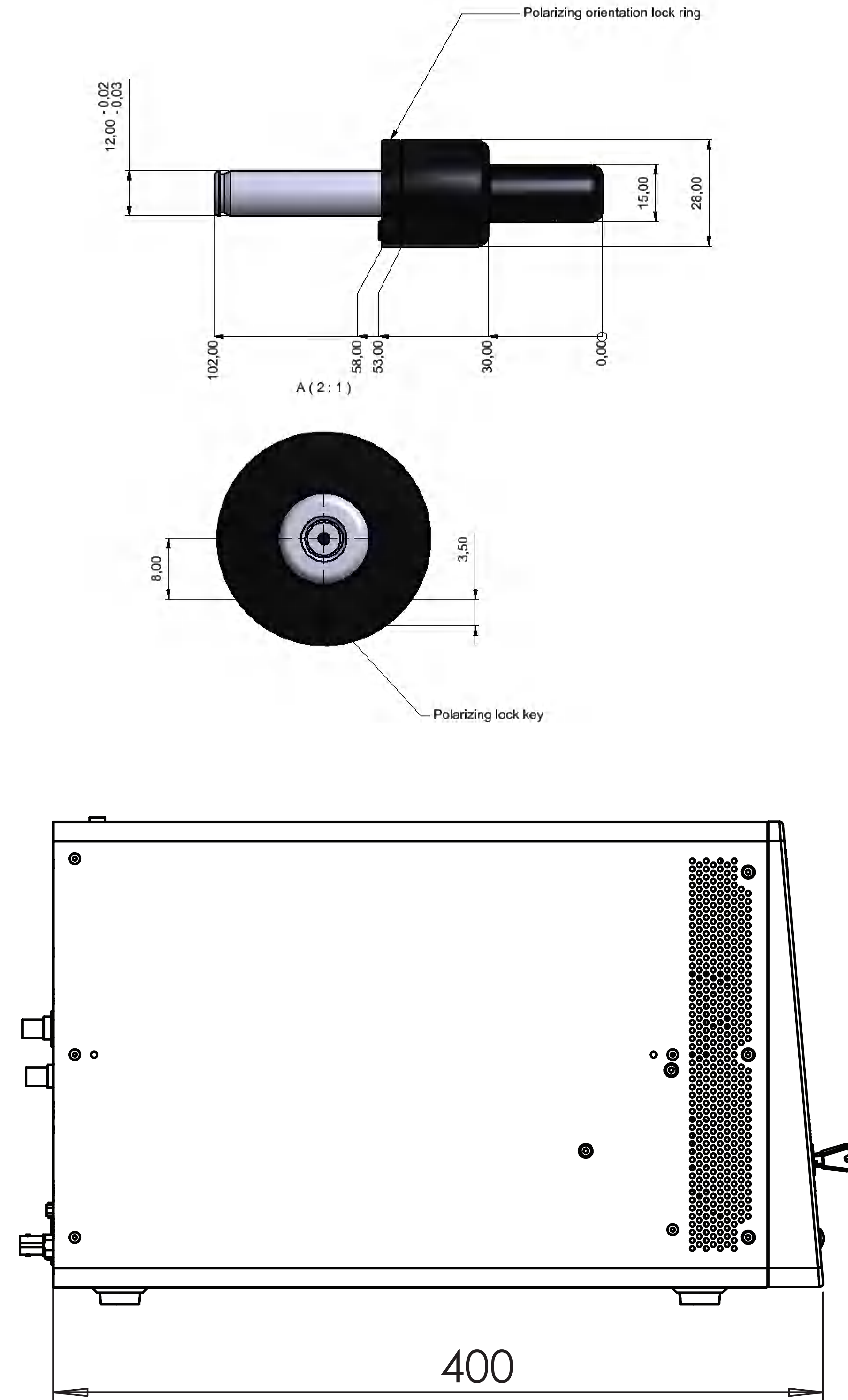
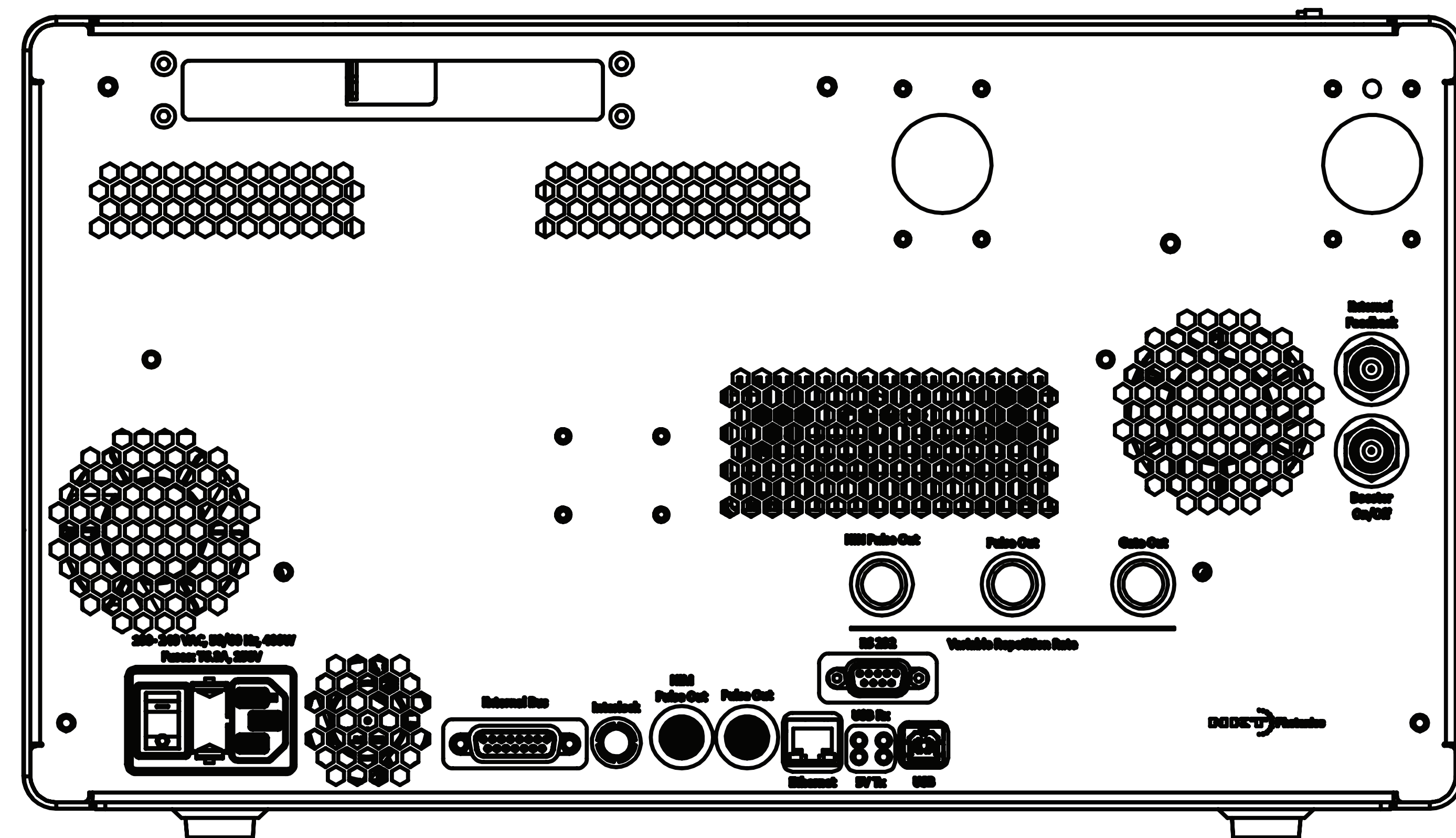
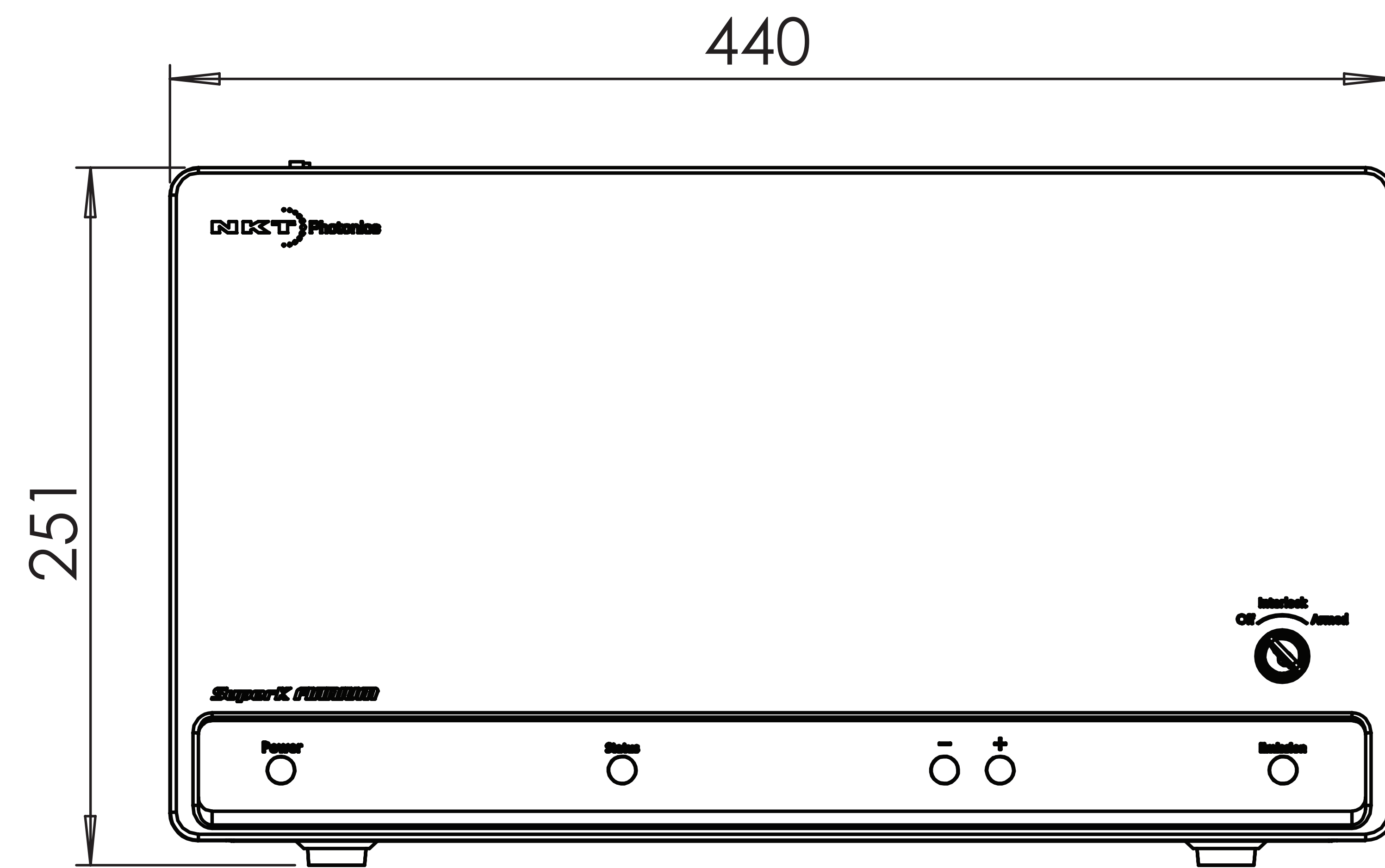

## SuperK FIANIUM

All NKT Photonics products are produced under our quality management system certified in accordance with the ISO 9001:2015 standard.



# SOLUTIONS FOR INNOVATORS

[nktphotonics.com](http://nktphotonics.com)

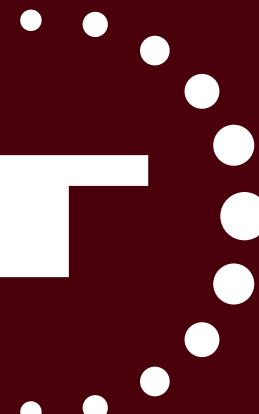
**NKT**  Photonics