

SuperK CHROMATUNE

The World's broadest tunable laser

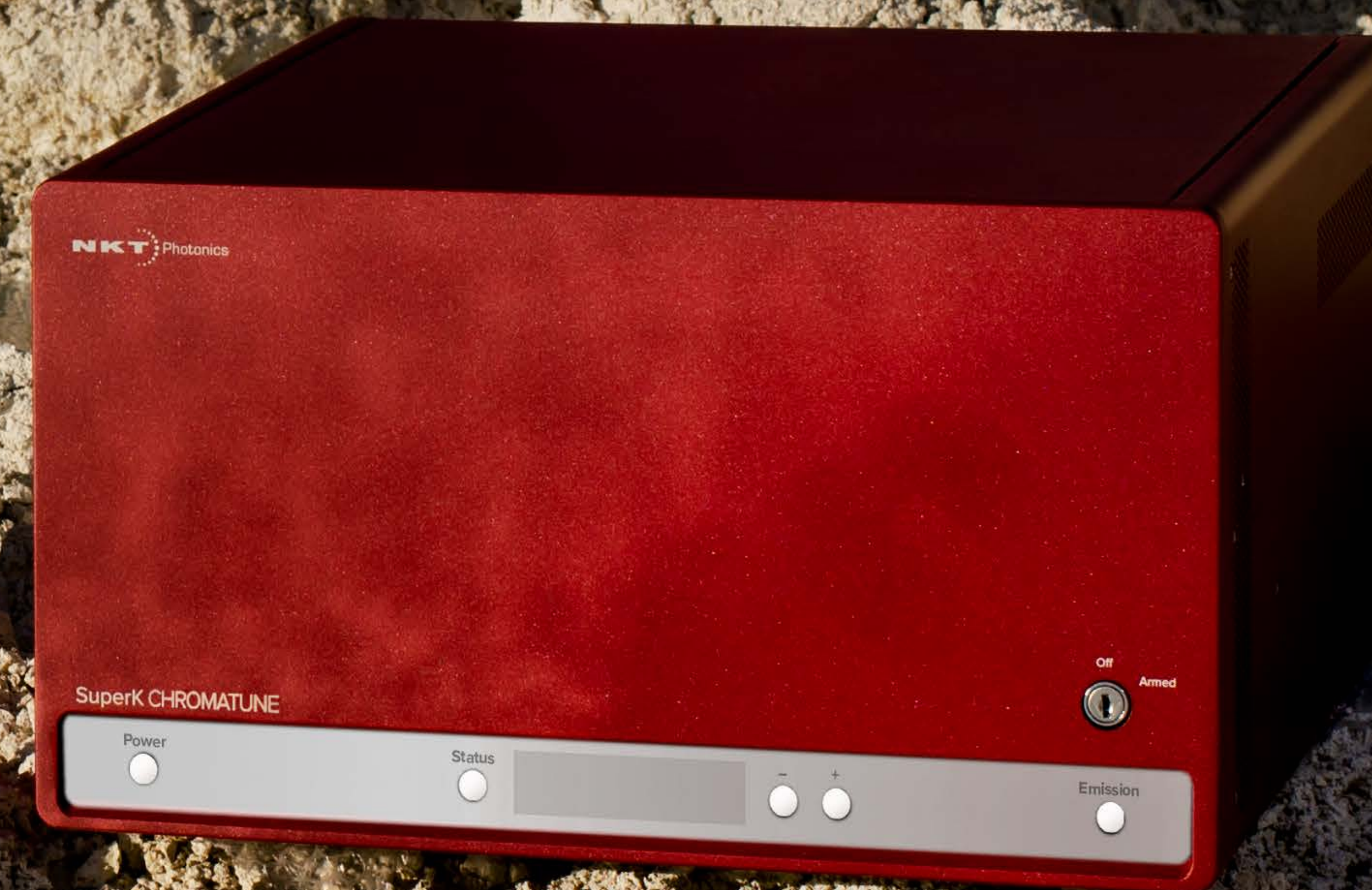

By the flip of a switch

Finally, a laser that is easy to use and lets you focus on your work.

Maybe saying that you will never need another laser is taking it too far, but... because of its broad 400–1000 nm tuning range, SuperK CHROMATUNE covers numerous of your wavelength needs. No alignment and no complex adjustments required. How to get started? Pick your wavelength and press the button to get instant light. It is that easy. Ready. Steady. Go.

SuperK CHROMATUNE is a versatile ultra-broadband tunable laser providing high brightness diffraction limited light in the 400-1000 nm wavelength range. The laser provides ultimate flexibility in terms of the wavelength, bandwidth, and power requirements. Whether you need a flat output power spectrum, a simulation of ambient light conditions or the visible part of the solar spectrum, CHROMATUNE can do it.

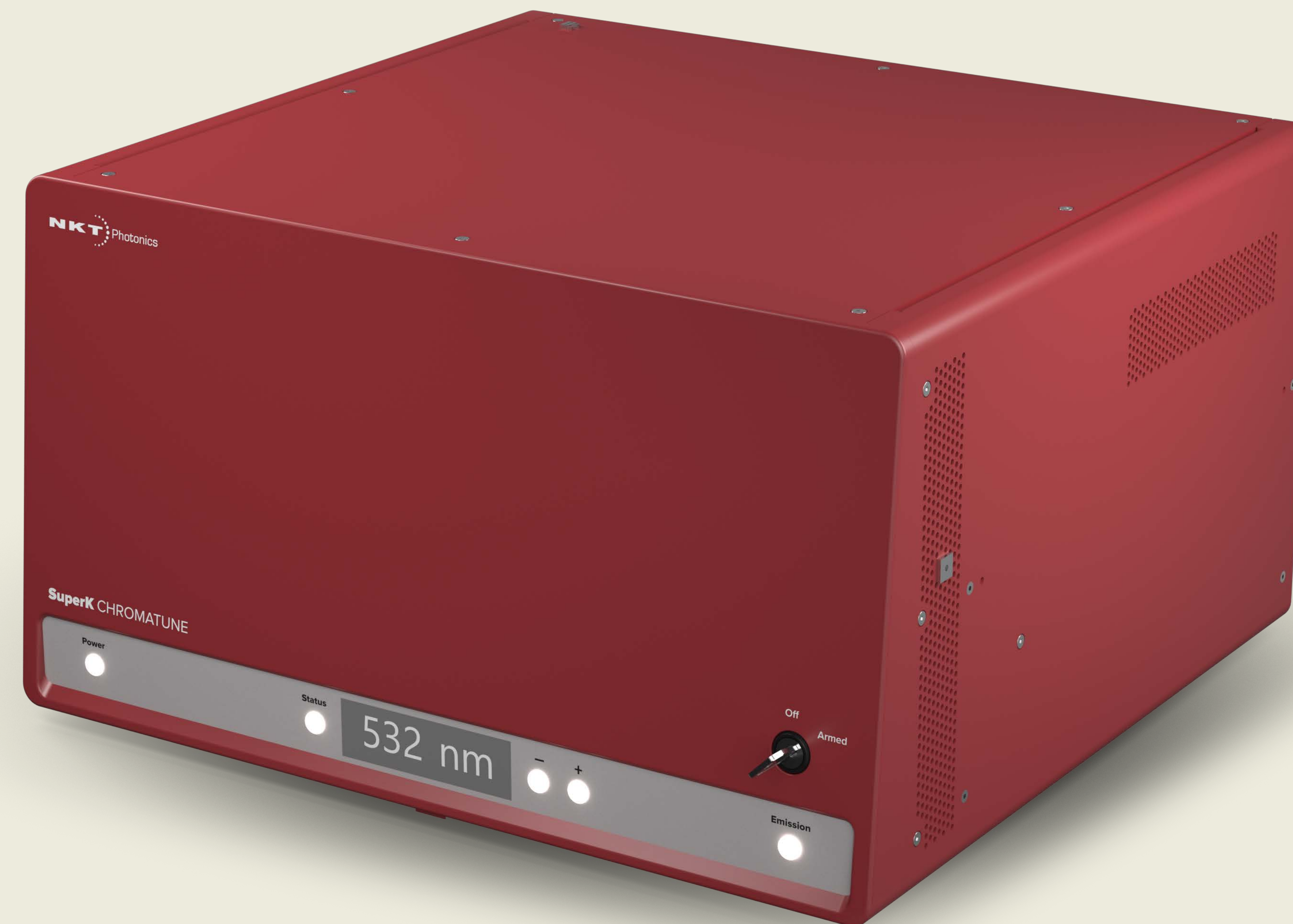

SuperK CHROMATUNE

Applications

Microscopy

Spectroscopy

Fluorescence

Lifetime Imaging

Optical characterization

Plasmonics & metamaterials

Ease of use

Operating the SuperK CHROMATUNE is easy for users from any discipline, no laser expertise is needed. The SuperK CONTROL graphical user interface on your PC gives intuitive control of all functions in the laser.

For advanced users, a full scripting functionality allows ultimate freedom in customizing the laser output for your application. Moreover, the SuperK CHROMATUNE is a class 3B laser lowering the laser safety requirements of your laboratory.

A maintenance-free lifetime of thousands of hours

The SuperK CHROMATUNE is based on NKT Photonics' world-renowned Crystal Fibre technology that has reliably delivered fiber lasers to various application fields for over 15 years. We also incorporate a state-of-the-art variable filter technology and an extremely user-friendly software to provide you with a versatile tunable laser.

For scientific applications, we offer a 2-year warranty. The system is fully modular, allowing easy service.

SuperK CHROMATUNE

NKT Photonics CONTROL

Like other NKT Photonics lasers, the SuperK CHROMATUNE can be controlled by our intuitive CONTROL software that gives easy access to all laser functions. The software automatically detects all units attached to the computer. It is easy to use and supports touch input as well as traditional mouse and keyboard control.



Options

Variable Repetition Rate (Pulse Picker)

The pulse picker option allows the repetition rate of the SuperK CHROMATUNE to be easily changed on-the-fly.

Repetition rates of 0.15-78 MHz are available as standard, giving the user ultimate choice for lifetime measurement applications such as FLIM. The electrical output trigger signal can be delayed up to 9.2 ns in steps of 15 ps.

This enables trigger delay optimization without the need for a delay box. The trigger is adjustable from the front panel.

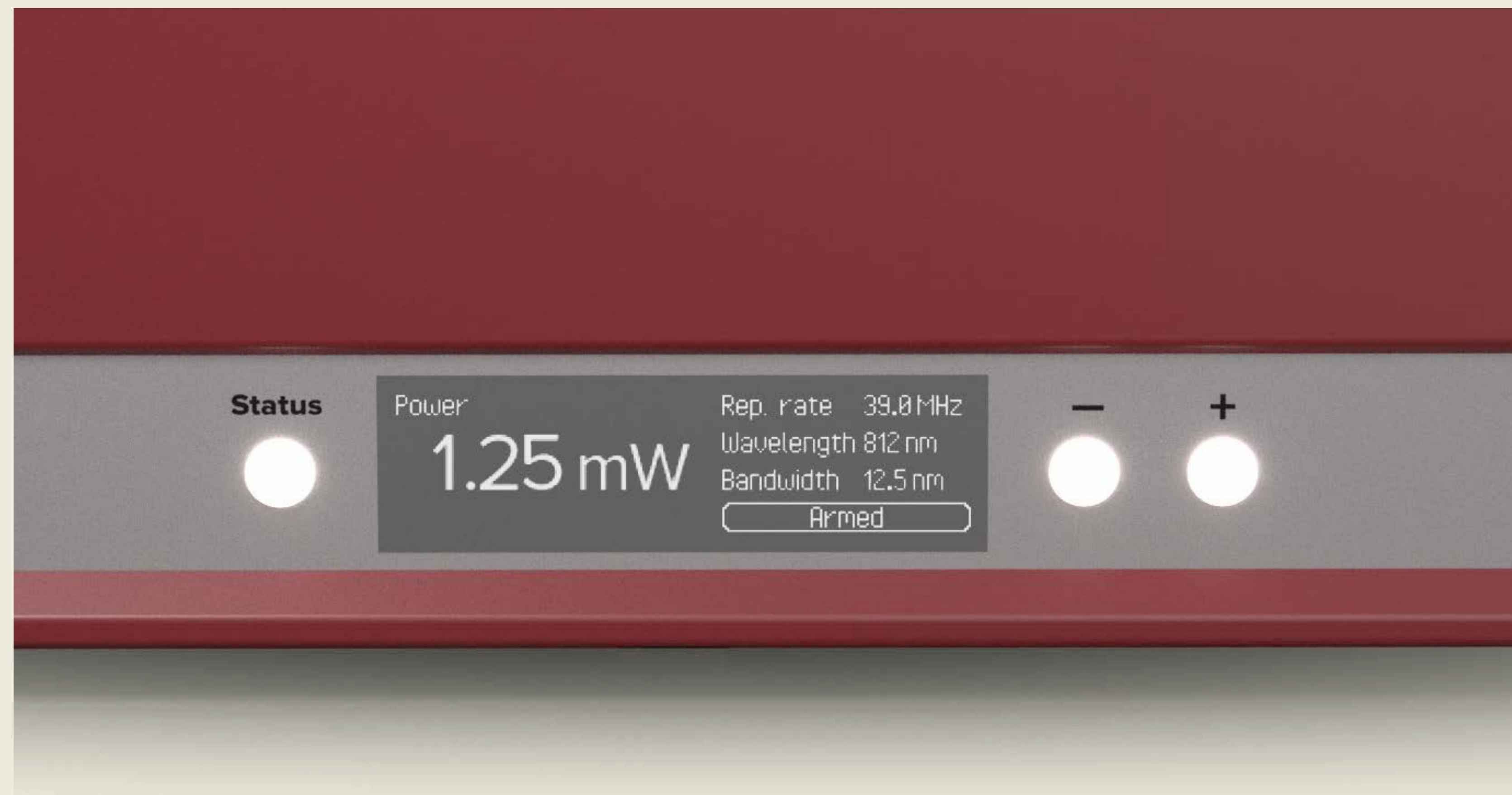

Repetition rate (fixed)	78 MHz
Variable repetition rate (optional)	0.15 - 78 MHz
Pulse suppression ratio	> 1:10,000
Repetition rate switching time	< 1 s
Trigger out signals	NIM, logic, analogue
Trigger signal jitter	< 20 ps
Adjustable trigger delay ¹	Up to 9.2 ns
Adjustable trigger delay resolution	15 ps

¹The electrical output trigger signal can be delayed up to 9.2 ns in steps of 15 ps.

SuperK CHROMATUNE

Support and warranty

SuperK CHROMATUNE comes with industry-leading reliability and are backed by our 2-year warranty for scientific applications.

Lifetime and service

Before shipping, all our SuperK lasers undergo an extensive burn-in to ensure performance and conformity to specifications. Our systems boast over 10,000 hours of continuous lifetime and underlines the high reliability of our NKT Photonics Crystal Fibre technology.

Maintenance-free

Completely maintenance-free in the entire lifetime.

Specifications

SuperK CHROMATUNE

Optical

Spectral coverage [nm]	400 - 1000
Output power per line [mW]	> 1
Power stability [%]	± 1
Repetition rate. Fixed / Variable [MHz]	78 / 0.15 - 78
Minimum bandwidth¹ / Maximum bandwidth [nm]	5-10 / 50
Out-of-band suppression² [dB]	> 40
Wavelength resolution [nm]	1.5
Wavelength step size [nm]	0.1
Full spectral scan speed³ [s]	~ 1
Beam output	Collimated armored fiber
Beam quality	Diffraction limited
Beam diameter [mm]	≈ 0.5 @ 400 nm ≈ 0.6 @ 600 nm ≈ 0.8 @ 800 nm ≈ 0.9 @ 1000 nm
Beam divergence [mrad]	< 1.5
Laser Class	3B

¹ Bandwidth increases with the wavelength. ² Measured within +/-20 nm from the center wavelength.
³ Time required for the laser to tune from one end of the spectrum to the other end.

Electrical/Mechanical

System cooling	Air
Operation temperature [°C]	18 - 30
Storage temperature [°C]	-10 - 55
Dimensions (WxHxL) [mm]	440 x 251 x 400
Weight [kg]	26 (fixed repetition rate) 27.5 (variable repetition rate)
Computer interface	USB 2.0/RS-232/Ethernet
Operation voltage	100-240 VAC 50/60 Hz
Power consumption [W]	< 175
Door interlock connector	2-pin LEMO
Sync (trigger) output	NM, analog pulse out, digital gate out (only for variable rep rate)

Software Development Kit (SDK)

The free software development kit (SDK) enables control of the SuperK CHROMATUNE laser using third party software and hardware.

The SDK contains a full description of the communication protocols as well as LabView drivers and C++/C# source code.

Technical Drawings

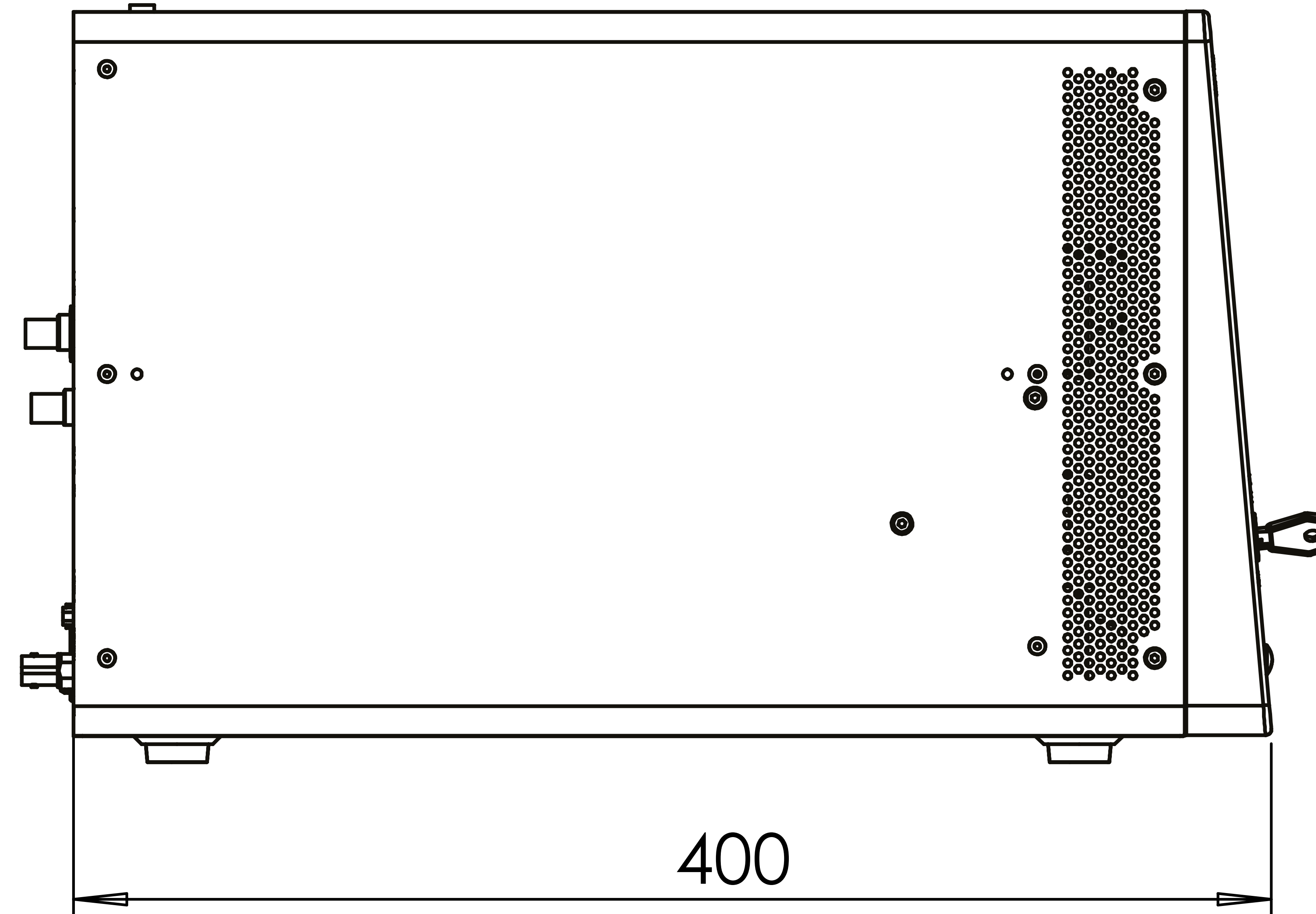
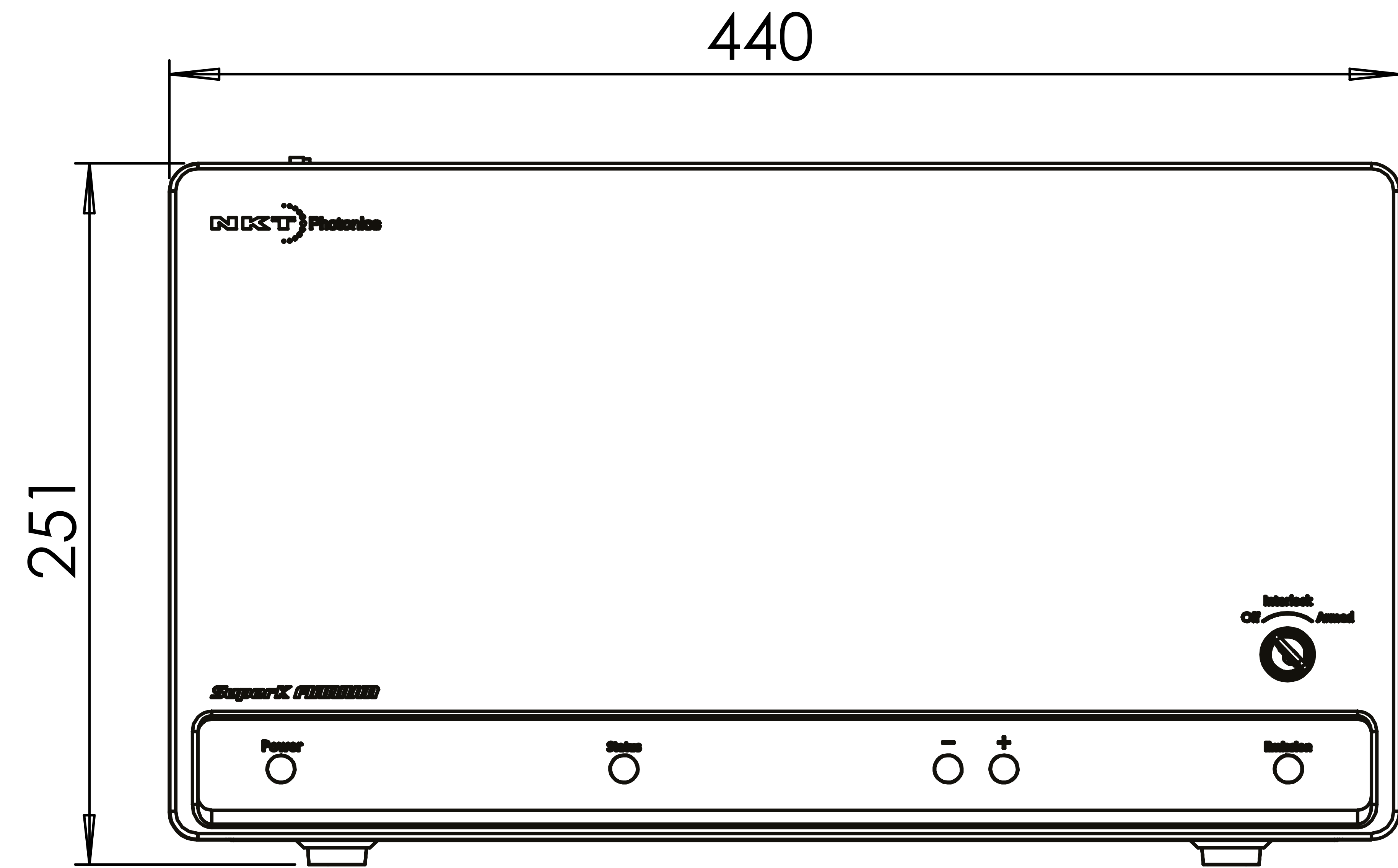

SuperK CHROMATUNE

All NKT Photonics products are produced under our quality management system certified in accordance with the ISO 9001:2015 standard.



© Copyright 2023 NKT Photonics AS. All Rights Reserved. SuperK CHROMATUNE_20230509

Technical Drawings

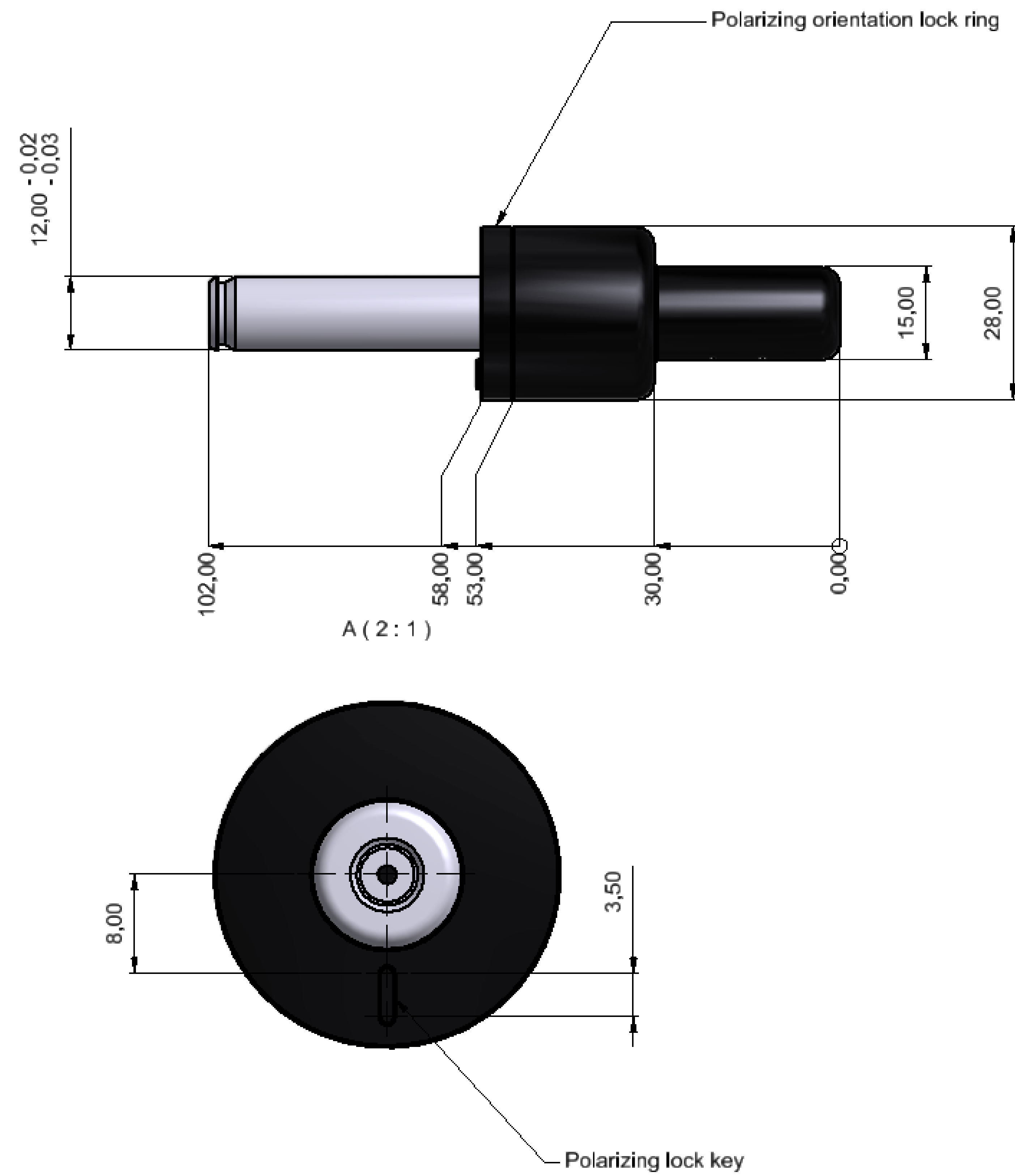

SuperK CHROMATUNE

All NKT Photonics products are produced under our quality management system certified in accordance with the ISO 9001:2015 standard.



SOLUTIONS FOR INNOVATORS