

LLTF CONTRAST

Tunable high-contrast single-line filter



CONTINUOUSLY TUNABLE HIGH-RESOLUTION BANDPASS FILTER

Ideal for visible and near-infrared spectra

The Laser Line Tunable Filter is a continuously tunable high-resolution bandpass filter which effectively converts a SuperK super-continuum source into a widely tunable picosecond laser.

The filter blocks unwanted lines with excellent out-of-band suppression while transmitting a single laser line with high efficiency.

Applications

- Fluorescence
- Flow cytometry
- Raman spectroscopy
- Fluorescence excitation and lifetime measurements

LLTF CONTRAST

Covers the spectrum from visible to infrared

The LLTF is a non-dispersive filter which maintains the intrinsic single-mode beam quality of the supercontinuum laser and consequently enables a wide range of applications.

With two wavelength tuning options, visible and near-infrared, the full spectrum of the supercontinuum is covered.

Adapts directly to the output collimator

The LLTF Contrast is compatible with all NKT Photonics supercontinuum lasers and is fully Plug and Play - adapting directly to the supercontinuum output collimator.

The output is also compatible with our precision fiber single-mode coupling unit, SuperK CONNECT, and SuperK fiber deliveries (we recommend FD7 for VIS and FD8 for SWIR).

Graphical user interface and software development kit

The LLTF can be operated through a user-friendly PHySpec software or a direct interface through the free software development kit.

Maintenance-free lifetime of thousands of hours

The all-fiber architecture ensures a stable 24/7 operation and a maintenance-free lifetime of thousands of hours backed by our 2-year warranty.

Model	Wavelength	Bandwidth	Power
VIS HP8	400-1000 nm	< 2.5 nm	8 W
SWIR HP8	1000-2300 nm	< 5 nm	8 W

Features

- Single channel tunable band-pass filter
- Exceptional out-of-band suppression
- Narrow line-width and high resolution
- Wideband tuning range across the visible and near-infrared range
- Simple and intuitive user interface
- Robust and compact industrial design
- Maintenance-free 24/7 operation

SPECIFICATIONS

Optical/Mechanical

Model	VIS	SWIR
Tunable wavelength range [nm]	400 – 1000	1000 – 2300
Channel spectral bandwidth, FWHM [nm]	1.0 – 2.5	2.0 – 5.0
Out-of-band suppression [dB]	60 @ ±40 nm	60 @ ±80 nm ¹⁾
Typical transmission efficiency [%]	65 %	65 %
Optical density	> OD6 @ 1064 nm	> OD6 @ 1064 nm
Damage threshold	< 5 GW/cm ² peak power @ 1064 nm, 8 ns	< 5 GW/cm ² peak power @ 1064 nm, 8 ns
Input aperture diameter [mm]	5 mm	5 mm
Input beam divergence requirement [mrad]	< 0.45	< 0.45
Wavelength resolution, relative	FWHM / 8	FWHM / 8
Pointing stability	< 1 mm lateral displacement @ 1 m from filter	< 1 mm lateral displacement @ 1 m from filter
Scanning speed stabilization time, multiple step [ms]	35 for 0.1 nm step 45 for 0.2 nm step 55 for 1 nm step 60 for 2 nm step 65 for 5 nm step 70 for 10 nm step	35 for 0.1 nm step 45 for 0.2 nm step 55 for 1 nm step 60 for 2 nm step 65 for 5 nm step 70 for 10 nm step
Interface	Graphical user interface via USB (optional SDK)	Graphical user interface via USB (optional SDK)
Interlock	Integrated	Integrated
Dimensions (WxHxL) [mm ³]	177.5 x 174 x 277.5	

1) Harmonic wavelengths <850 nm will be present in the output. We recommend an external clean-up long-pass filter if the detector is sensitive to visible wavelengths.

TECHNICAL DRAWINGS

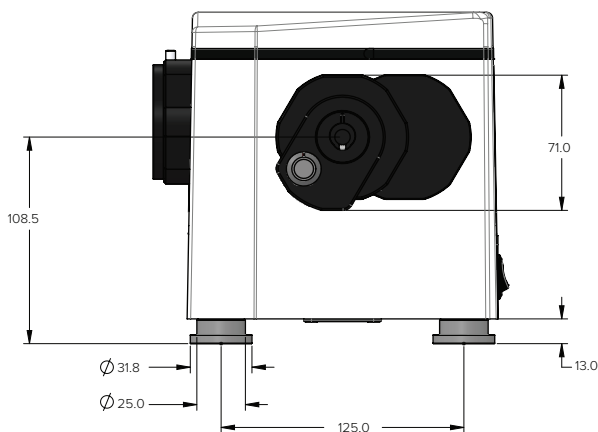
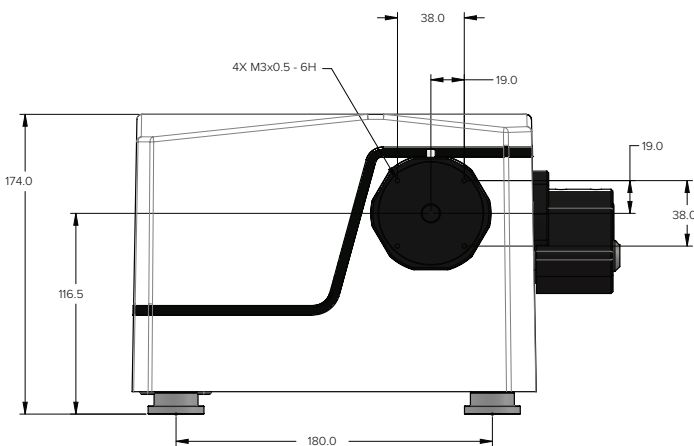
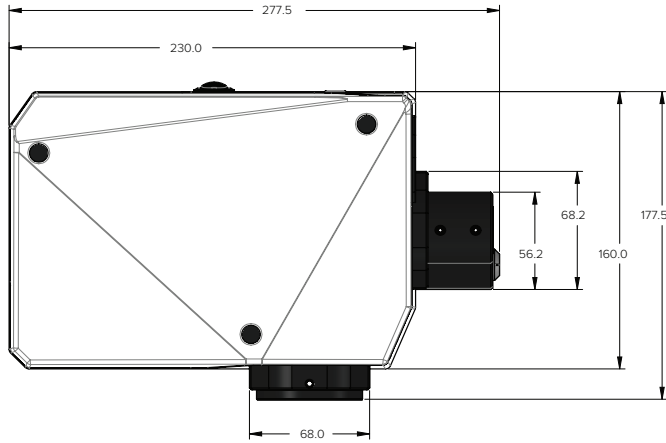

Support and warranty

Warranty

All LLTF products come with industry leading reliability and are backed by our standard 2 year warranty.

Lifetime and service

Before shipping, all our LLTF products undergo an extensive hours burn-in to ensure performance and conformity to specifications.

Our systems boast over 10,000 hours of continuous lifetime and underline the high reliability of our NKT Photonics Crystal Fibre technology.

Maintenance-free in the entire lifetime

All LLTF products are completely maintenance-free in the entire lifetime.

Should your filter be damaged, the modular platform ensures fast turnaround on service and repairs. Typically, it takes four weeks or less to get your laser back.

All NKT Photonics products are produced under our quality management system certified in accordance with the ISO 9001:2015 standard.

