

1064nm High Power Polarization Maintaining Isolator——Type A43/B43

Features

Low Insertion Loss
High Power Handling
High Isolation

Applications

Optical Fiber Amplifier
Instruments
Fiber Laser
Sensor Systems

Specifications

Parameters	Unit	Values	
		A43	B43
Isolator Type		A43	B43
Center Wavelength	nm	1064	
Operating Wavelength Range	nm	±5	
Typ. Peak Isolation	dB	35	
Min. Isolation at 23℃	dB	28	
Typ. Insertion Loss at 23℃	dB	1.6	1.7
Max. Insertion Loss at 23℃	dB	1.8	1.9
Max. Insertion Loss at 1064nm @ 1.0W , 23℃	dB	2.0	2.1
Max. Insertion Loss at 1064nm @ 1.5W , 23℃	dB	2.5	2.3
Max. Insertion Loss at 1064nm @ 2.0W , 23℃	dB	--	2.5
Min. Return Loss (Input/Output)	dB	50/50	
Min. ER at 23℃ (F-Type)	dB	22	
Min. ER at 23℃ (B-Type)	dB	20	
Max. Optical Average Power (CW)	W	1.0 or specify	2.0 or specify
Max. Peak Power for ns Pulse	kW	10 @ 1ns	
Max. Tensile Load	N	5	
Operating Temperature	℃	-5 to +50	
Storage Temperature	℃	-20 to +75	

*Above specifications are for device without connector.

*For devices with connectors, IL will be 0.7dB higher, RL will be 5dB lower, ER will be 2dB lower and optical power is only 1W (CW).

*The PM fiber and connector key are aligned to the slow axis.

*The material must be RoHS compliant.

Package Dimensions

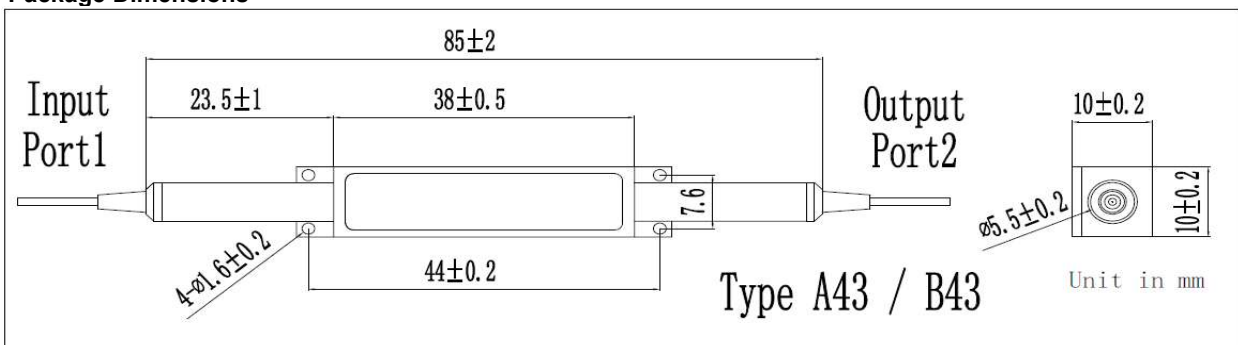

Ordering Information

HPMI-①①-②②②-③③-④-⑤⑤-⑥⑥-⑦-⑧⑧

①①: Wavelength
06 - 1064nm

②②②: Package Type
A43 - Type A43
B43 - Type B43

③③: Handling Power
01 - 1W
02 - 2W

④: Axis Alignment
F - Fast Axis Blocked
B - Both Axis Working

⑤⑤: Connector Type on Port 1 & 2
1A - FC/UPC
2A - FC/APC(Step)
3A - SC/UPC
4A - SC/APC(Step)
N - None
S - Specify

⑥⑥: Fiber Jacket on Port 1 & 2
B - 250um Bare Fiber
C - 900um Loose Tube(Red)
S - Specify

⑦: Fiber Length
1 - 1.0m
S - Specify

⑧⑧: Fiber Type
1 - PM980 Fiber
S - Specify