

Features

High Power Handling
 Compact High Performance
 High Extinction Ratio
 Low Insertion Loss
 High Power Handling Capability

Applications

Polarization Mode Dispersion Compensator
 EDFA & Raman Amplifier
 Coherent Telecommunication Systems
 Fiber Optic Sensor
 High Directivity

Specifications

Parameter	Unit	Values	
		Single stage	Dual stage
Center Wavelength	nm	1310, 1480 or 1550	
Operating Wavelength Range	nm	±40	
Typ. Insertion loss	dB	0.65	0.75
Max. Insertion loss	dB	0.9	1.0
Typ. Isolation	dB	38	52
Min. Isolation @23°C	dB	20	42
Min. Extinction Ratio (for Splitter only)	dB	20	20
Min. Return Loss	dB	50	
Min. Directivity	dB	50	
Max. Optical Power (CW)	W	1, 3, 5 or Specify	
Max. Peak Power for ns Pulse	kW	10	
Max. Tensile Load	N	5	
Fiber Type		PM Panda Fiber on Port 1 and 2, SMF-28e Fiber or PM Panda Fiber on Port 3	
Operating Temperature	°C	-5 to +70	
Storage Temperature	°C	-40 to +85	

*Above specifications are for device without connector.

*For devices with connectors, IL will be 0.3dB higher, RL will be 5dB lower and ER will be 2dB lower and optical power is only 1000mW(CW).

*The PM fiber and the connector key are aligned to the slow axis.

Package Dimensions

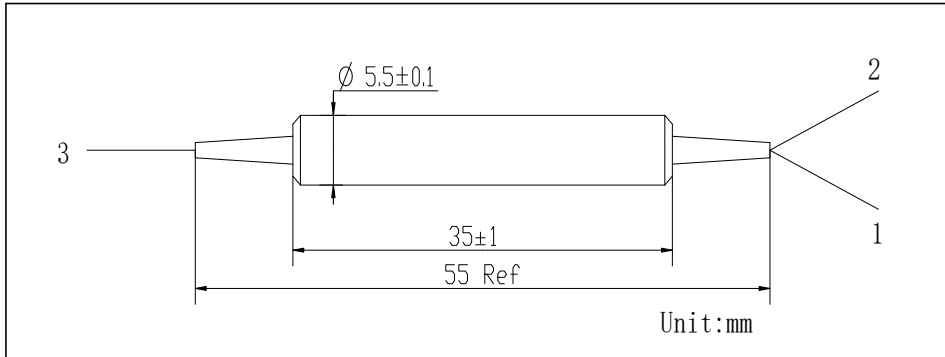

Ordering Information

HIPBC-①①-②-③③-④④④-⑤⑤⑤-⑥-⑦

HIPBS-①①-②-③③-④④④-⑤⑤⑤-⑥-⑦

①①: Wavelength

31 - 1310nm

48 - 1480nm

55 - 1550nm

SS - Specify

②: Stage

S - Single Stage

D - Dual Stage

③③: Handling Power

01 - 1W

SS - Specify

④④④: Connector Type on Port 1, 2 & 3

1 - FC/UPC

2 - FC/APC

3 - SC/UPC

4 - SC/APC

N - None

S - Specify

⑤⑤⑤: Fiber Jacket on Port 1, 2 & 3

B - 250um Fiber

L - 900um Loose Tube

S - Specify

⑥: Fiber Type on Port 3

1 - SMF-28e Fiber

2 - Slow axis align 45° to Port 1

3 - Slow axis align to Port 1

4 - All ports are SMF-28e

S - Specify

⑦: Fiber Length

0.8 - 0.8m

S - Specify