

25Gb/s BiDi 40km 1270nm/1310nm

FEATURES

- Supports bit rates up to 28Gbps
- -0°C to +70°C operating case temperature
- SFP28 package with single LC receptacle connector
- Hot-pluggable capability
- Single 3.3V power supply
- 1270nm/1310nm Un-cooled DFB transmitter and high performance APD receiver
- Up to 40km transmission distance over SMF
- Low power dissipation
- SFI electrical interface
- Low EMI and excellent ESD protection
- Built- in Digital Diagnostic Monitoring (DDM) function
- Class I laser safety standard IEC-60825 compliant
- RoHS-6 compliance

APPLICATIONS

- 25-Gigabit Ethernet
- CPRI

STANDARDS

- Complies with SFP28 MSA (SFF-8402)
- Complies with SFF-8472
- Compliant with CPRI 7.0
- Complies with FCC 47 CFR Part 15, Class B
- Complies with 21 CFR 1040.10 and 1040.11 except for deviations pursuant to Laser Notice No. 50, dated June 24, 2007

ABSOLUTE MAXIMUM RATING

Parameter	Symbol	Min.	Max.	Unit	Notes
Storage Ambient Temperature	TSTG	-40	85	°C	
Operating Humidity	OH	0	95	%	
Power Supply Voltage	VCC	-0.3	3.6	V	
Damage receive power threshold		-3		dBm	

RECOMMENDED OPERATING CONDITION

Parameter	Symbol	Min.	Typ.	Max.	Unit	Notes
Operating Case Temperature	T _c	0		70	°C	
Power Supply Voltage	VCC	3.13	3.3	3.47	V	
Power Supply Consumption	P			1.2	W	
Data Rate		24.3	25.78	28.05	Gbps	CDR Enable
Link Distance				40	km	Single Mode Fiber (SMF)

TRANSMITTER OPTICAL CHARACTERISTICS

Parameter	Symbol	Min.	Typ.	Max.	Unit	Notes
Centre Wavelength	λ_C	1300	1310	1320	nm	SO0432FF-PLIGA
		1260	1270	1280	nm	SO0423FF-PLIGA
Average Output Power	POUT	-2		4	dBm	Launched into SMF Fiber
Average Power of OFF Transmitter	POUT-OFF			-35	dBm	

Extinction Ratio	ER	3.5			dB	
Optical return loss tolerance		20			dB	
Transmitter eye mask definition {X1, X2, X3, Y1, Y2, Y3}		{0.31, 0.4, 0.45, 0.34, 0.38,0.4}				

TRANSMITTER ELECTRICAL CHARACTERISTICS

Parameter		Symbol	Min.	Typ.	Max.	Unit	Note
Differential input eye height from host			200		900	mVpp	
Input Differential Impedance			85	100	115	Ω	
TX Disable	Disable		2		VCC+0.3	V	
	Enable		-0.3		0.8	V	
TX Fault	Fault		2.4		VCCH OST	V	
	Normal		-0.3		0.4	V	

RECEIVER OPTICAL CHARACTERISTICS

Parameter	Symbol	Min.	Typ.	Max.	Unit	Notes
Operating Wavelength	λ_C		1270		nm	SO0432 FF- PLIGA
			1310			SO0423 FF- PLIGA
Sensitivity(OmA)	SEN(OMA)			-18	dBm	PRBS2 ³¹ - 1@25.78 Gbps; BER ≤5E-5;
Saturation Optical Power	SAT	-5			dBm	
LOS De-Assert	LOSD			-20	dBm	
LOS Assert	LOSA	-30			dBm	
LOS Hysteresis	HYS	0.5		5	dB	

RECEIVER ELECTRICAL CHARACTERISTICS

Parameter	Symbol	Min.	Typ.	Max.	Unit	Notes
Differential data output swing	Vout	300		1000	mVpp	
Rx_LOS Output Voltage - High	High	2.4		VCCH OST	V	
Rx_LOS Output Voltage - Low	Low	-0.3		0.4	V	

PIN DESCRIPTION			
PIN	Name	Description	Notes
1	VEET	Transmitter Ground	
2	TX_Fault	Transmitter Fault Indication	Low: normal; High: abnormal
3	TX_Disable	Transmitter Disable	Low: transmitter on; High: transmitter off
4	SDA	SDA	The data line of two wire serial interface
5	SCL	SCL	The clock line of two wire serial interface
6	MOD_ABS	Module Absent	Connected to VEET or VEER in the module
7	RS0	Not Connected	
8	RX_LOS	Loss of Signal	Low: signal detected; High: loss of signal
9	RS1	Not Connected	
10	VEER	Receiver Ground	
11	VEER	Receiver Ground	
12	RD-	Inv. Received Data Out	AC-coupled, CML
13	RD+	Received Data Out	AC-coupled, CML
14	VEER	Receiver Ground	
15	VCCR	Receiver Power	
16	VCCT	Transmitter Power	
17	VEET	Transmitter Ground	
18	TD+	Transmit Data In	AC-coupled, CML
19	TD-	Inv. Transmit Data In	AC-coupled, CML
20	VEET	Transmitter Ground	

PIN OUT DRAWING (TOP VIEW)

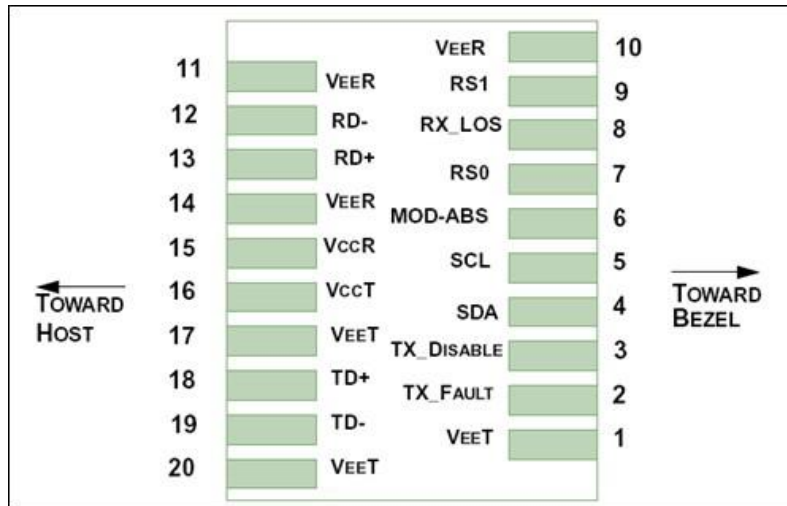

Figure 1 Pin Out Drawing (Top view)

TYPICAL INTERFACE CIRCUIT

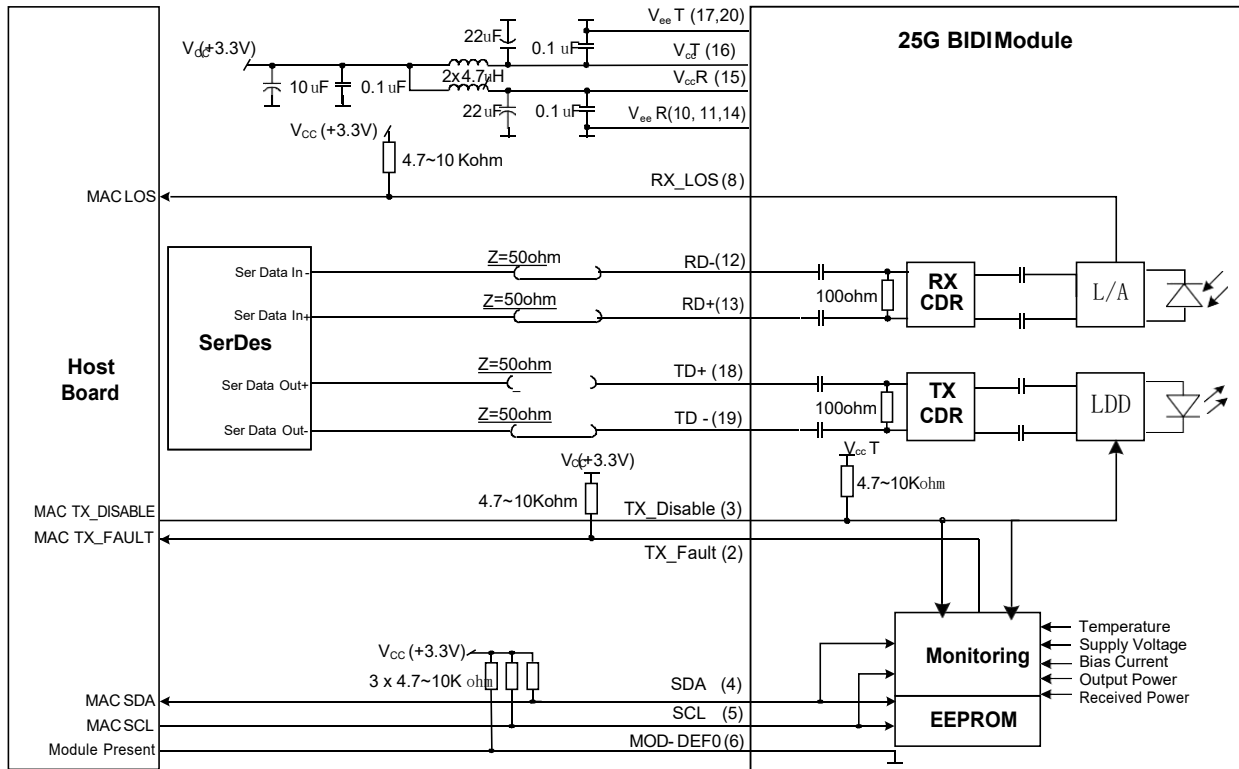

Figure 2 Typical Interface Circuit

PACKAGE OUTLINE

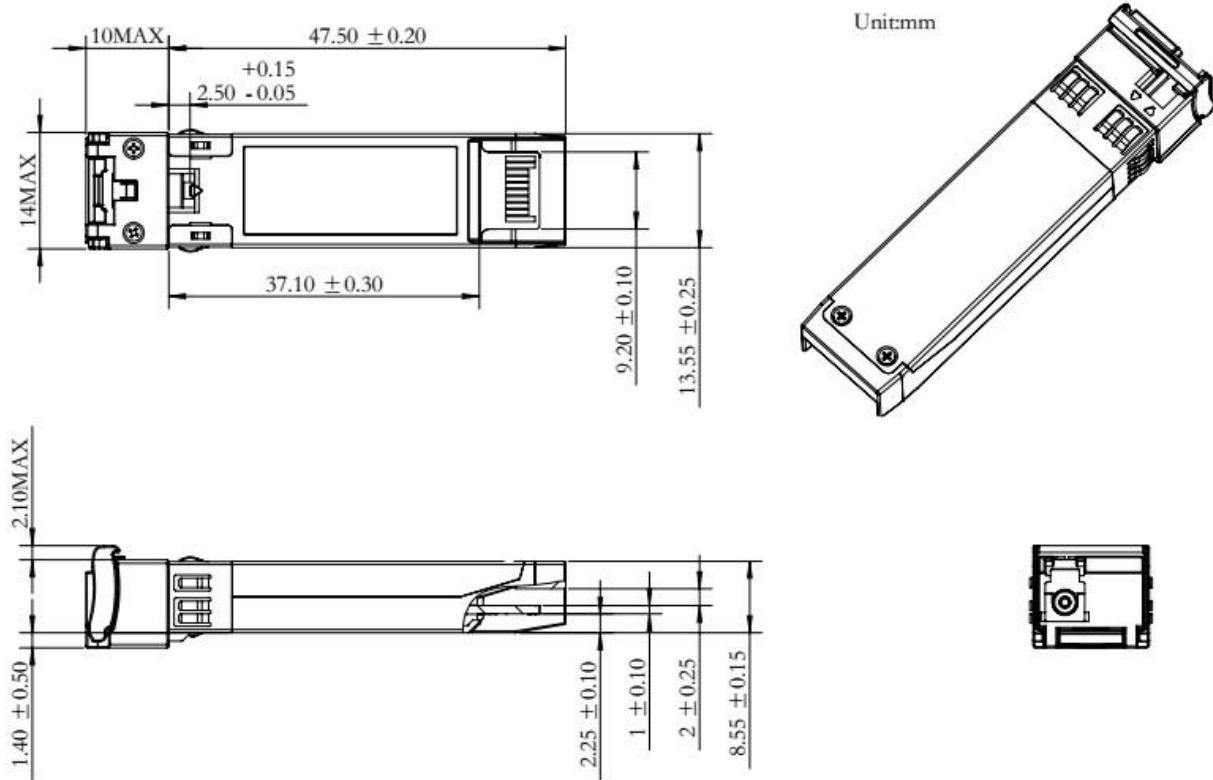

Figure 3 Package Outline

EEPROM INFORMATION

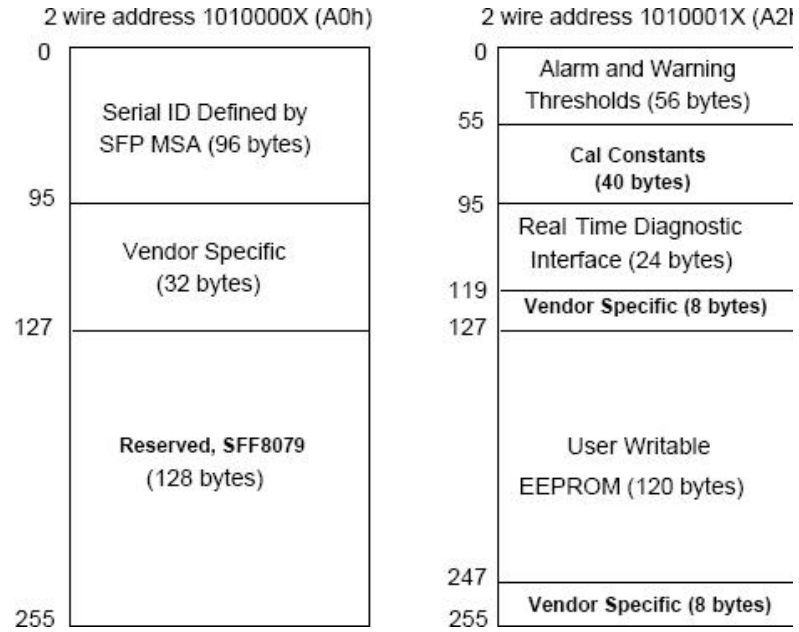

Figure 4 EEPROM Memory Map Specific Data Field Descriptions

DIGITAL DIAGNOSTIC MONITORING INTERFACE

Parameter	Range	Accuracy	Calibration	NOTES
Temperature	0 to 70°C	±5°C	Internal	LSB: 1/256C
Voltage	2.97 to 3.63V	±3%	Internal	LSB: 0.1mV
Bias Current	0 to 100mA	±10%	Internal	LSB: 2uA
TX Power	-3 to +5dBm	±3dB	Internal	LSB: 0.1uW
RX Power	-19 to -4dBm	±3dB	Internal	LSB: 0.1uW

WARNINGS

- Handling Precautions: This device is susceptible to damage as a result of electrostatic discharge (ESD). A static free environment is highly recommended. Follow guidelines according to proper ESD procedures.
- Laser Safety: Radiation emitted by laser devices can be dangerous to human eyes. Avoid eye exposure to direct or indirect radiation.

All rights reserved.