

Product Specification

10Gb/s DWDM 80km Multi-Rate Tunable SFP+ Transceiver

E-temp versions: FTLX6871MNC and FTLX6872MNC

PRODUCT FEATURES

- Hot-pluggable SFP+ footprint
- Supports 8.5 and 9.95 to 11.3 Gb/s
- Up to 80km link length
- 50GHz ITU-based channel spacing (C-Band) with a wavelength locker
- -5 /+85°C case temperature range
- Single 3.3V power supply
- Monolithic MZM Tunable TOSA
- Linear or Limiting electrical interface receiver
- Duplex LC connector
- Built-in digital diagnostic functions
- RoHS-6 compliant (lead-free)



APPLICATIONS

- DWDM 80km point to point links:
 - 8G Fibre Channel
 - 10Gb/s SONET/SDH
 - 10G Ethernet
 - 10G Fibre Channel
- ITU-T G.698.1 DS100S1-2Dz(C)
- ITU-T G.709

Finisar’s FTLX6871MNC and FTLX6872MNC transceivers are Enhanced Small Form Factor Pluggable Tunable SFP+ transceivers designed for use in 10-Gigabit multi-rate links up to 80km of G.652 single mode fiber. They are compliant with SFF-8431¹, SFF-8432², SFF-8690⁸, and G.698.1 DS100S1-2Dz(C), and support SONET OC-192, SDH STM-64, 10G Ethernet ZR and 10G Fibre Channel over 80km fiber. Digital diagnostics functions are available via a 2-wire serial interface, as specified in SFF-8472³. The optical transceiver is compliant per the RoHS Directive 2011/65/EU⁴. See Finisar Application Note AN-2038⁵ for more details.

PRODUCT SELECTION

Product Part Number	RX Interface
FTLX6871MNC	Linear
FTLX6872MNC	Limiting

I. Pin Descriptions

Pin	Symbol	Name/Description	Ref.
1	V _{EET}	Transmitter Ground	1
2	T _{FAULT}	Transmitter Fault	2
3	T _{DIS}	Transmitter Disable. Laser output disabled on high or open.	3
4	SDA	2-wire Serial Interface Data Line	2
5	SCL	2-wire Serial Interface Clock Line	2
6	MOD_ABS	Module Absent. Grounded within the module	2
7	NA	Not Used	
8	RX_LOS	Loss of Signal indication. Logic 0 indicates normal operation.	4
9	NA	No Used	
10	V _{EER}	Receiver Ground	1
11	V _{EER}	Receiver Ground	1
12	RD-	Receiver Inverted DATA out. AC Coupled.	
13	RD+	Receiver Non-inverted DATA out. AC Coupled.	
14	V _{EER}	Receiver Ground	1
15	V _{CCR}	Receiver Power Supply	5
16	V _{CCT}	Transmitter Power Supply	5
17	V _{EET}	Transmitter Ground	1
18	TD+	Transmitter Non-Inverted DATA in. AC Coupled.	
19	TD-	Transmitter Inverted DATA in. AC Coupled.	
20	V _{EET}	Transmitter Ground	1

Notes:

1. Circuit ground is internally isolated from chassis ground.
2. T_{FAULT} is an open collector/drain output, which should be pulled up with a 4.7k – 10k Ohms resistor on the host board if intended for use. Pull up voltage should be between 2.0V to V_{cc} + 0.3V. A high output indicates a transmitter fault caused by either the TX bias current or the TX output power exceeding the preset alarm thresholds. A low output indicates normal operation. In the low state, the output is pulled to <0.8V.
3. Laser output disabled on T_{DIS} >2.0V or open, enabled on T_{DIS} <0.8V.
4. LOS is open collector output. Should be pulled up with 4.7k – 10kΩ on host board to a voltage between 2.0V and 3.6V. Logic 0 indicates normal operation; logic 1 indicates loss of signal.
5. Internally connected

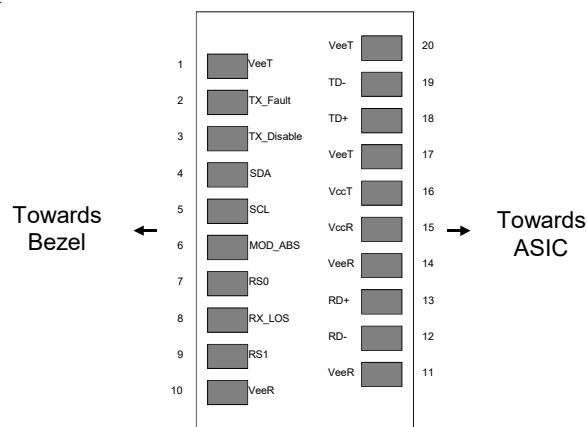

Figure 1. Diagram of Host Board Connector Block Pin Numbers and Names.

II. Absolute Maximum Ratings

Exceeding the limits below may damage the transceiver module permanently.

Parameter	Symbol	Min	Typ	Max	Unit	Ref.
Maximum Supply Voltage	V _{cc}	-0.5		4.0	V	
Storage Temperature	T _s	-40		85	°C	
Relative Humidity	RH	0		85	%	1
Receiver Optical Damage Threshold	RX _{Damage}	5			dBm	

Notes:

1. Non-condensing

III. Electrical Characteristics (T_{OP} = -5 to +85 °C)

Parameter	Symbol	Min	Typ.	Max	Unit	Ref.
Supply Voltage	V _{cc}	3.14		3.46		
Supply Current	I _{cc}			800	mA	1
Module total power dissipation	P			2.5	W	2
Transmitter						
Input differential impedance	R _{in}	80	100	120	Ω	
Differential data input swing	V _{in,pp}	200		850	mV	3
Transmit Disable Voltage	V _D	V _{cc} -0.8		V _{cc}	V	
Transmit Enable Voltage	V _{EN}	V _{ee}		V _{ee} + 0.8	V	
Receiver						
Output differential impedance	R _{out}	80	100	120	Ω	
Differential data output swing (Rx input power -18dBm to -7dBm)	V _{out,pp}	150		850	mV	4
Output rise time and fall time	T _r , T _f	28			ps	4,5
LOS asserted	V _{LOS_A}	V _{cc} -0.8		V _{cc}	V	
LOS de-asserted	V _{LOS_D}	V _{ee}		V _{ee} +0.8	V	
Power Supply Noise Tolerance	V _{ccT} /V _{ccR}	Per SFF-8431 Rev 4.1			mV _{pp}	

Notes:

1. Compliant with the SFP+ Module Power Supply Requirements defined in [1], Tab. 8.
2. Maximum total power value is specified across the full temperature and voltage range.
3. Connected directly to TX data input pins.
4. Into 100Ω differential termination.
5. 20 – 80%. Measured with Module Compliance Test Board and OMA test pattern. Use of four 1's and four 0's sequence in the PRBS 9 is an acceptable alternative. SFF-8431 Rev 4.1.

IV. Optical Characteristics (TOP = -5 to +85 °C, VCC = 3.14 to 3.46 Volts)

Parameter		Symbol	Min	Typ	Max	Unit	Ref.
Transmitter (Tx)							
Average Launch Power		P_{AVE}	-1		+3	dBm	
Optical Wavelength		λ_c	As per ITU-T 694.1, 50GHz spacing 1528.77 to 1563.86			nm	
Side-Mode Suppression Ratio		SMSR	30			dB	
Optical Extinction Ratio		ER	8.2			dB	
Average Launch power when Tx is OFF		P_{OFF}			-30	dBm	
Tx Jitter 20kHz - 80MHz		T_{Xj1}			0.3	UI	
Tx Jitter 4MHz - 80MHz		T_{Xj2}			0.1	UI	
Relative Intensity Noise		RIN			-128	dB/Hz	
Center Wavelength	Beginning of Life	λ_{c_BOL}	z-1.5	z	z+1.5	GHz	
	End of Life	λ_{c_EOL}	z-2.5	z	z+2.5	GHz	
Receiver (Rx) at 0ps/nm							
Bit rate		BER					
8.5, 9.95		<1E-12	R_{SENS1}			-24.0	dBm 1,2
10.7 Gb/s		<1E-12	R_{SENS2}			-23.0	dBm 1,2
11.1 Gb/s		<1E-4	R_{SENS3}			-27.0	dBm
11.3 Gb/s		<1E-4	R_{SENS4}			-27.0	dBm
Overload (Average Power)		P_{AVE}				-7	dBm
Optical Center Wavelength		λ_c	1260			1600	nm
LOS De-Assert		LOS _D				-25	dBm
LOS Assert		LOS _A	-34			-27	dBm
LOS Hysteresis		LOS _H	0.5				dB
Receiver Reflectance		R_{RX}				-27	dB

FTLX6871/72MNC					
Receiver Sensitivity³					
Data rate (Gb/s)	BER	Dispersion (ps/nm)	Sensitivity back-to-back at OSNR>30dB (dBm)	Dispersion Penalty at OSNR>30dB (dB)	Threshold Adjust Required
9.95	1e-12	-300 to 1450	-24	2	No ⁵
10.3	1e-12	-300 to 1450	-23	2.5	No ⁵
10.7	1e-4	-300 to 1300	-27	3	Yes ⁶
11.1	1e-4	-300 to 1300	-27	3	Yes ⁶
11.3	1e-4	-300 to 1300	-27	3.5	Yes ⁶
OSNR Performance⁴					
Data rate (Gb/s)	BER	Dispersion (ps/nm)	Min OSNR Back-to-back at Power: -18dBm to -7dBm (dB)	Max OSNR Penalty at Power: -18 to -7dBm (dB)	Threshold Adjust Required
9.95	1e-12	-300 to 1450	24	4	Yes ⁶
10.3	1e-12	-300 to 1450	24	4	Yes ⁶
10.7	1e-4	-300 to 1300	16	4	Yes ⁶
11.1	1e-4	-300 to 1300	16	4	Yes ⁶
11.3	1e-4	-300 to 1300	17	4	Yes ⁶

Notes:

1. Measured with worst ER=8.2dB; BER<10⁻¹²; 2³¹ – 1 PRBS.
2. For 10GEthernet application, -24dBm is equivalent to an OMA of -22.09dBm for an ER = 8.2 dB.
3. Measured at 1528-1600nm with worst ER; PRBS31.
4. All OSNR measurements are performed with 0.1nm resolution.
5. Linecard SerDes input threshold adjustment required (set to 50%) at 9.95 and 10.3Gb for AGC ROSA only
6. Linecard SerDes input threshold adjustment required for AGC ROSA. RxDTV control required for Limiting ROSA

V. General Specifications

Parameter	Symbol	Min	Typ	Max	Units	Ref.
Bit Rate	BR	8.5		11.3168	Gb/s	1
Max. Supported Link Length	L _{MAX}			80	km	2

Notes:

1. Tested with a $2^{31} - 1$ PRBS pattern at the BER defined in Table IV.
2. Over G.652 single mode fiber.

VI. Timing Parameters

Parameter	Symbol	Min	Max	Units	Ref.
Time to initialize cooled module	t _{start up cooled}		90	s	

VII. Environmental Specifications

Finisar FTLX6871/72MNC transceivers have an operating temperature range from -5°C to +85°C case temperature.

Parameter	Symbol	Min	Typ	Max	Units	Ref.
Case Operating Temperature	T _{op}	-5		85	°C	
Storage Temperature	T _{sto}	-40		85	°C	

VII. Regulatory Compliance

Finisar transceivers are Class 1 Laser Products and comply with US FDA regulations. These products are certified by TÜV and CSA to meet the Class 1 eye safety requirements of EN (IEC) 60825 and the electrical safety requirements of EN (IEC) 60950. Copies of certificates are available at Finisar Corporation upon request.

VIII. Digital Diagnostic Functions

Finisar FTLX6871/72MNC Tunable SFP+ transceivers support the 2-wire serial communication protocol as defined in the SFP MSA¹. It is very closely related to the memory map defined in the GBIC standard, with the same electrical specifications.

The standard SFP serial ID provides access to identification information that describes the transceiver's capabilities, standard interfaces, manufacturer, and other information.

Additionally, Finisar T-SFP+ transceivers provide an enhanced digital diagnostic monitoring interface, which allows real-time access to device operating parameters such as transceiver temperature, laser bias current, transmitted optical power, received optical power and transceiver supply voltage. It also defines a sophisticated system of alarm and warning flags, which alerts end-users when particular operating parameters are outside of a factory set normal range.

The SFP MSA defines a 256-byte memory map that is accessible over a 2-wire serial interface at the 8 bit address 1010000X (A0h). The digital diagnostic monitoring interface makes use of the 8 bit address 1010001X (A2h), so the originally defined serial ID memory map remains unchanged. The interface is identical to, and is thus fully backward compatible with both the GBIC Specification and the SFP Multi Source Agreement.

The operating and diagnostics information is monitored and reported by a Digital Diagnostics Transceiver Controller (DDTC) inside the transceiver, which is accessed through a 2-wire serial interface. When the serial protocol is activated, the serial clock signal (SCL, Mod Def 1) is generated by the host. The positive edge clocks data into the SFP transceiver into those segments of the E²PROM that are not write-protected. The negative edge clocks data from the SFP transceiver. The serial data signal (SDA, Mod Def 2) is bi-directional for serial data transfer. The host uses SDA in conjunction with SCL to mark the start and end of serial protocol activation. The memories are organized as a series of 8-bit data words that can be addressed individually or sequentially.

IX. Digital Diagnostic Specifications

FTLX6871/72MNC transceivers can be used in host systems that require either internally or externally calibrated digital diagnostics.

Parameter	Symbol	Units	Min	Max	Accuracy	Ref.
Accuracy						
Transceiver temperature	$\Delta DDTemp$	°C	-10	+90	±5°C	1
Transceiver supply voltage	$\Delta DDVoltage$	V	2.8	4.0	±3%	
Transmitter bias current	$\Delta DDBias$	mA	0	127	±10%	2
Transmitter output power	$\Delta DDTx-Power$	dBm	-1	+5	±2dB	
Receiver average optical input power	$\Delta DDRx-Power$	dBm	-28	-5	±2dB	

Notes:

1. Internally measured
2. The accuracy of the Tx bias current is 10% of the actual current from the laser driver to the laser

X. Start-Up Sequence

The FTLX6871/72MNC modules adhere to MSA SFF-8690 for wavelength / channel selection of these tunable modules. The module behavior is described in the flowchart below:

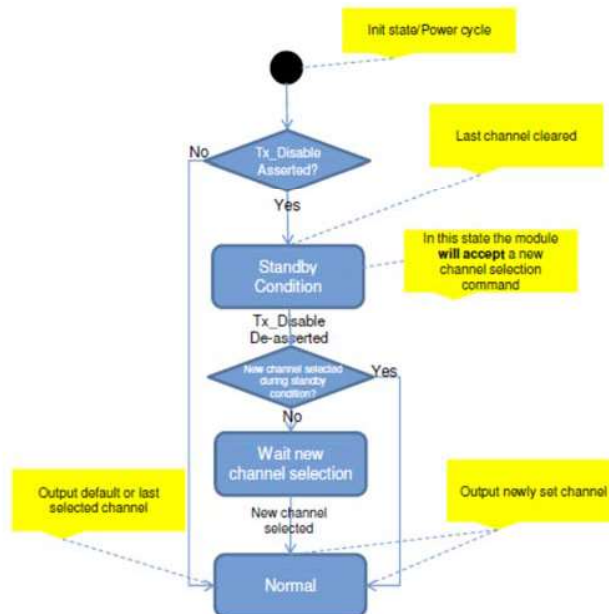

Alarm and Warning Threshold Values (A2h)

Address	Parameter	Threshold Values	UNITS
00-01	Temp High Alarm	90	C
02-03	Temp Low Alarm	-15	C
04-05	Temp High Warning	88	C
06-07	Temp Low Warning	-10	C
08-09	Voltage High Alarm	3.56	V
10-11	Voltage Low Alarm	3.04	V
12-13	Voltage High Warning	3.46	V
14-15	Voltage Low Warning	3.14	V
16-17	Bias High Alarm	130	mA
18-19	Bias Low Alarm	5	mA
20-21	Bias High Warning	120	mA
22-23	Bias Low Warning	10	mA
24-25	TX Power High Alarm	6.5	dBm
26-27	TX Power Low Alarm	-3	dBm
28-29	TX Power High Warning	6	dBm
30-31	TX Power Low Warning	-1.5	dBm
32-33	RX Power High Alarm	-4	dBm
34-35	RX Power Low Alarm	-31	dBm
36-37	RX Power High Warning	-5	dBm
38-39	RX Power Low Warning	-25	dBm
40-55	Reserved		

XI. The FTLX6871/72MNC modules do not contain Internal CDRs.

XII. SFF-8431 Power-up Sequence

The typical power consumption of the FTLX6871/72MNC exceeds the limit of 1.5W specified in the SFF-8431 for the Power Level II device, for which the SFF-8431 recommends a power-up sequence. Per the SFF-8431, at the power-on a Power Level II transceiver can stay in Power Level I until the host enables the transceiver to complete its power-up sequence, reaching its operating power consumption into Power Level Mode II. Please, refer to SFF-8431 and Finisar Application Note AN-2076⁷ for additional details. The FTLX6871/72MNC is factory set to power-up directly to its operating conditions in Power Level Mode II. Upon request, it can be factory set to follow the above power-up sequence at the power-on. In power level I, the FTLX6871/72MNC does not carry traffic, but the 2-wire serial communication is active.

XIII. Mechanical Specifications

Finisar FTLX6871/72MNC SFP+ transceivers are compatible with the SFF-8432 specification for improved pluggable form factor, and shown here for reference purposes only. Bail color is green.

ITEM	DIM (mm)	TOL (mm)
A	9.00	±0.3
B	9.60	±0.5
C	11.90	±0.5
D	13.85	±0.15
E	13.65	±0.15
F	2.80	±0.2
G	1.00	±0.2
H	4.00	REF
J	2.00	±0.2
K	56.50	REF
L	1.60	±0.5
M	2.25	±0.1
N	1.80	±0.1
P	37.10	±0.3
Q	9.15	±0.15
R	1.00	±0.1
S	8.55	±0.15
T	47.50	±0.2
V	2.55	±0.1
W	43.00	±0.2
X	14.70	±0.5
Z	0.55	±0.15

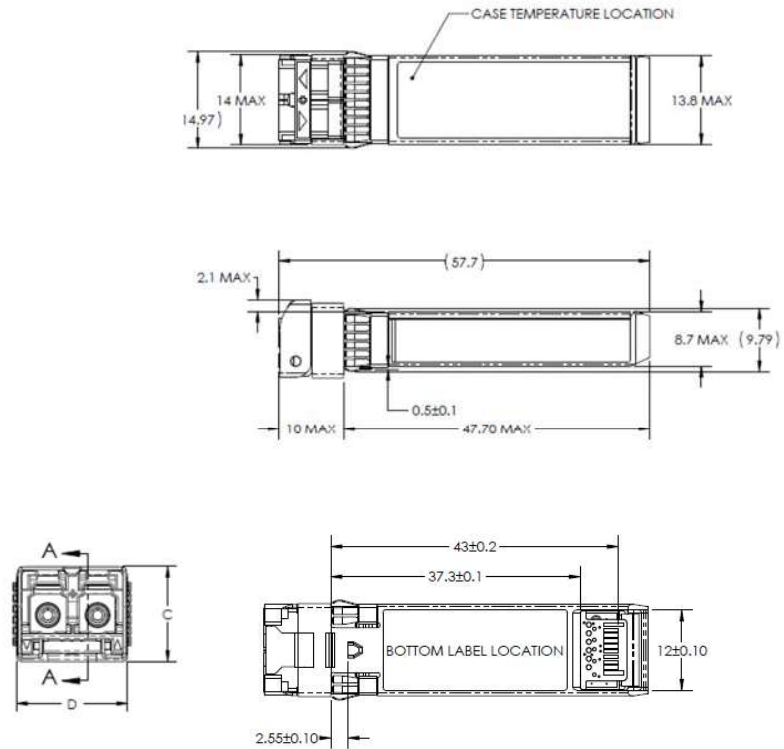

Figure 2. Mechanical Dimensions

Connector Recommendations

Product Label and Box Label

These are “subject to change without notice” and being used as a guideline for the format.



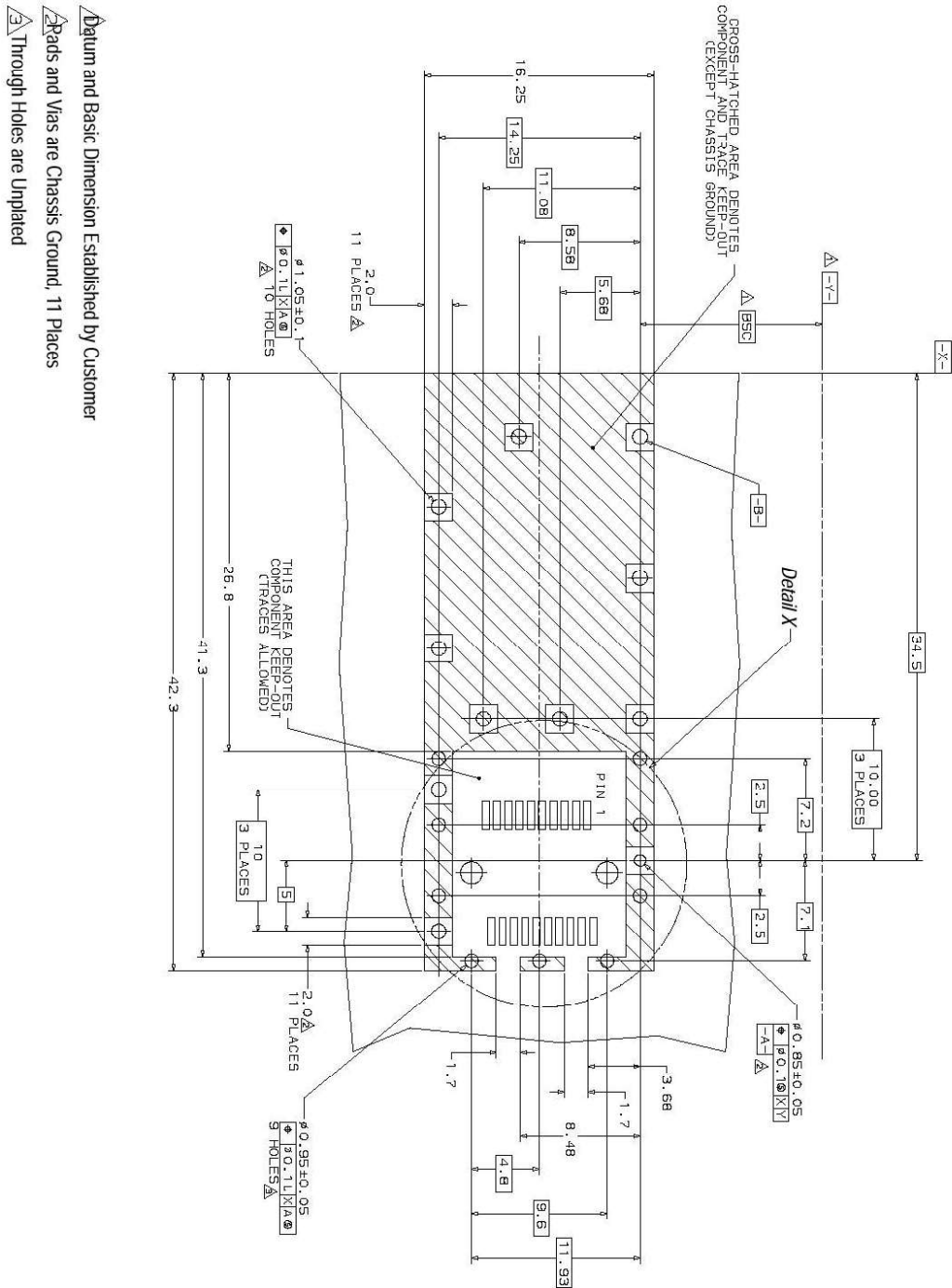
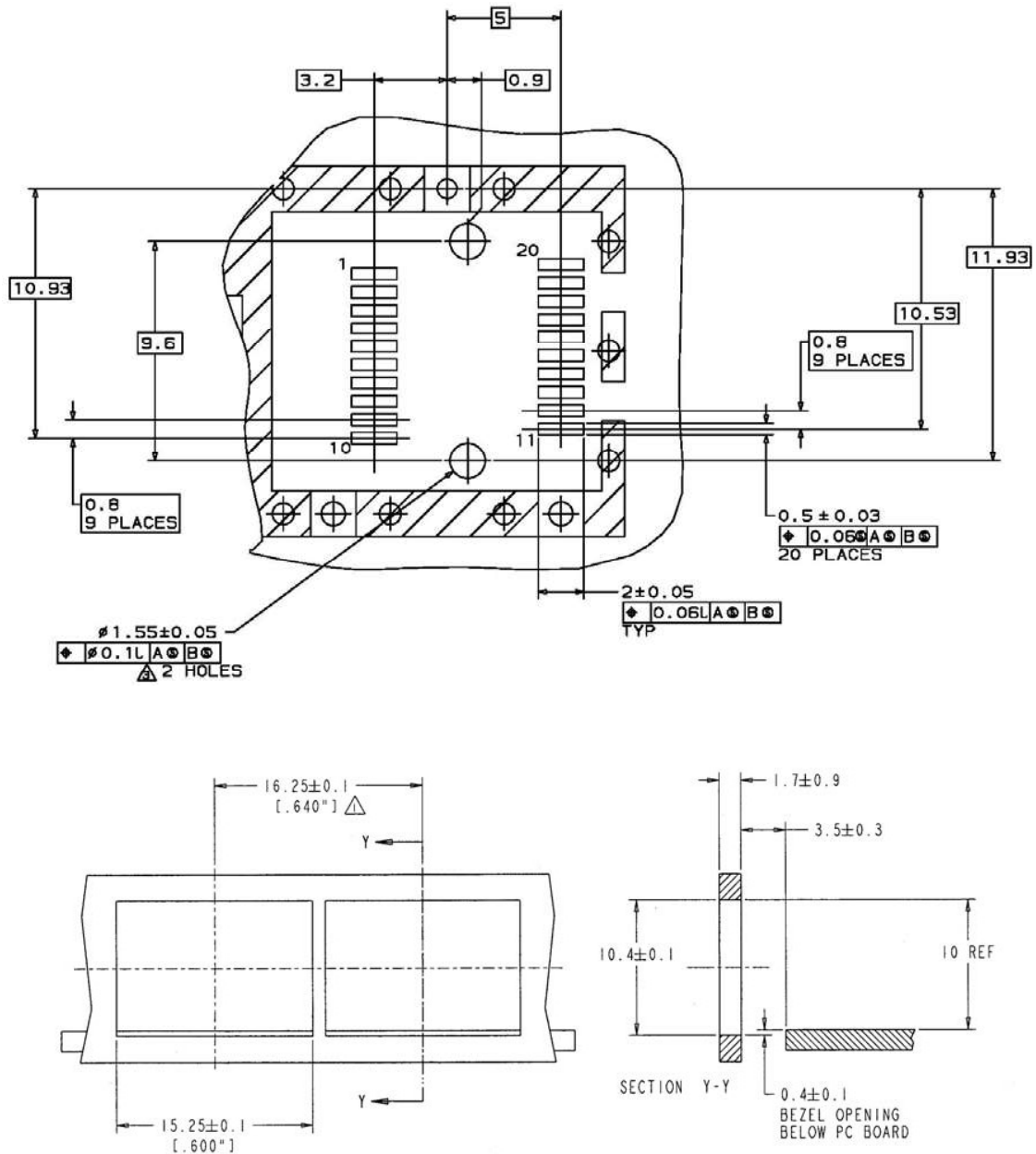

Figure 3. PCB Layout and Bezel Recommendations, as per [9]

- Datum and Basic Dimension Established by Customer
- Pads and Vias are Chassis Ground, 11 Places
- Through Holes are Unplated



- NOTES:
- 1. MINIMUM PITCH ILLUSTRATED, ENGLISH DIMENSIONS ARE FOR REFERENCE ONLY
 - 2. NOT RECOMMENDED FOR PCI EXPANSION CARD APPLICATIONS

Figure 4

XV. Host-Module Interface Diagram

To Be Provided in future release.

Figure 5

XVI. References

1. “Specifications for Enhanced 8.5 and 10 Gigabit Small Form Factor Pluggable Module ‘SFP+ ‘”, SFF Document Number SFF-8431, Revision 4.1 (or later).
2. “Improved Pluggable Form factor”, SFF Document Number SFF-8432, Revision 4.2, April 18, 2007 (or later).
3. “Digital Diagnostics Monitoring Interface for Optical Transceivers”. SFF Document Number SFF-8472, Revision 11.3, (or later).
4. Directive 2011/65/EU of the European Council Parliament and of the Council, “on the restriction of the use of certain hazardous substances in electrical and electronic equipment”
5. “Application Note AN-2038: Finisar Implementation of RoHS Compliant Transceivers”, Finisar Corporation, January 21, 2005.
6. Small Form-factor Pluggable (SFP) Transceiver Multi-Source Agreement (MSA)
7. “Application Note AN-2076: SFP+ Level II Power Up Sequence”, Rev B
8. Tunable SFP+ MSA; SFF-8690

XVII. Revision History

Revision	Date	Description
A00	8/18/2015	Initial Release
A01	12/08/2015	Change the product image on page 1. Add product and box label samples on mechanical Specifications section.
A02	March 2017	Corrected Max current to support 2.5W total power consumption of module.
A03	April 2017	Corrected RoHS statements to reference 2011 directive

XVIII. For More Information

Finisar Corporation
1389 Moffett Park Drive
Sunnyvale, CA 94089-1133
Tel. 1-408-548-1000
Fax 1-408-541-6138
sales@finisar.com
www.finisar.com