

## SFP-10G-T 10GBASE-T Copper SFP+ Transceiver

### PRODUCT FEATURES

- Support 10Gbase-T / 5Gbase-T / 2.5Gbase-T / 1000base-T
- Hot-pluggable SFP footprint
- Compact RJ-45 connector assembly
- RoHS compliant and lead-free
- Single +3.3V power supply
- 10 Gigabit Ethernet over Cat 6a cable
- Ambient Operating temperature: 0° C to +65° C
- Maximum power consumption: 2W
- electric current: 700MA



### PRODUCT DESCRIPTION

SFP+-10GBASE-T Copper Small Form Pluggable (SFP) transceivers are based on the SFP Multi Source Agreement (MSA) . They are compatible with the 10Gbase-T / 5Gbase-T / 2.5Gbase-T / 1000base-T standards as specified in IEEE Std 802.3 . SFP+-10GBASE-T uses the SFP's RX\_LOS(must be pulled up on host) pin for link indication. If pull up or open SFP's TX\_DISABLE pin, PHY IC be reset.

## 1.Cable Length

Standard	Cable	Reach	Host Port
10Gbase-T	CAT6A	30m	10GBase-R
5Gbase-T/2.5Gbase-t	CAT5E	50m	5GBase-R/2. 5GBase-X
1000base-T	CAT5E	100m	1000base-FX

## 2.SFP to Host Connector Pin Out

Pin	Symbol	Name/Description	Ref.
1	VEET	Transmitter Ground (Common with Receiver Ground)	1
2	TFAULT	Transmitter Fault. Not supported.	
3	TDIS	Transmitter Disable. Laser output disabled on high or open.	2
4	MOD_DEF(2)	Module Definition 2. Data line for Serial ID.	3
5	MOD_DEF(1)	Module Definition 1. Clock line for Serial ID.	3
6	MOD_DEF(0)	Module Definition 0. Grounded within the module.	3
7	Rate Select	No connection required	
8	LOS	High indicates no linked. low indicates linked.	
9	VEER	Receiver Ground (Common with Transmitter Ground)	1
10	VEER	Receiver Ground (Common with Transmitter Ground)	1
11	VEER	Receiver Ground (Common with Transmitter Ground)	1
12	RD-	Receiver Inverted DATA out. AC Coupled	
13	RD+	Receiver Non-inverted DATA out. AC Coupled	
14	VEER	Receiver Ground (Common with Transmitter Ground)	1
15	VCCR	Receiver Power Supply	
16	VCCT	Transmitter Power Supply	
17	VEET	Transmitter Ground (Common with Receiver Ground)	1
18	TD+	Transmitter Non-Inverted DATA in. AC Coupled.	
19	TD-	Transmitter Inverted DATA in. AC Coupled.	
20	VEET	Transmitter Ground (Common with Receiver Ground)	1

Notes:

1. Circuit ground is connected to chassis ground
2. PHY disabled on TDIS > 2.0V or open, enabled on TDIS < 0.8V
3. Should be pulled up with 4.7k - 10k Ohms on host board to a voltage between 2.0 V and 3.6 V. MOD\_DEF(0) pulls line low to indicate module is plugged in.

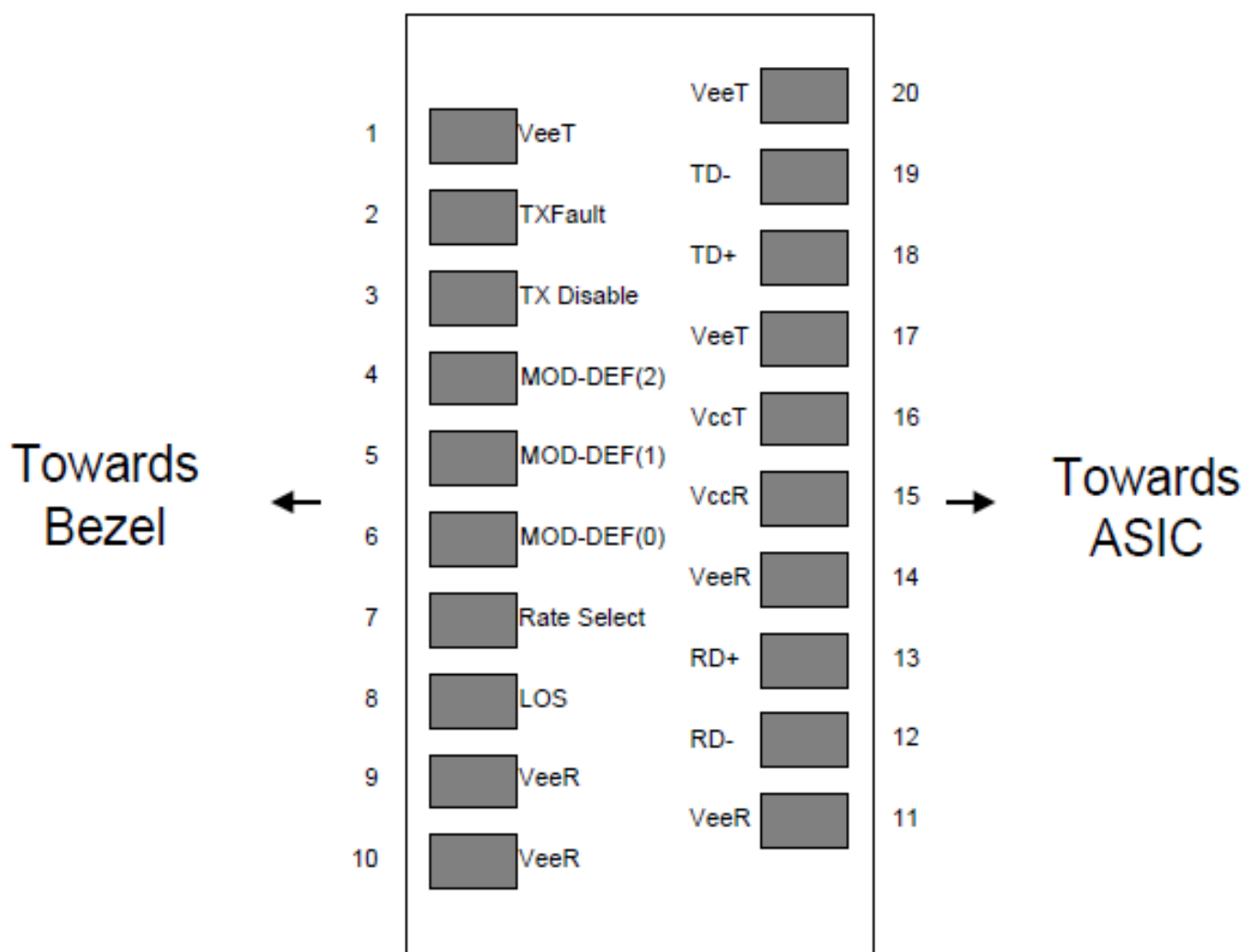

Figure 1. Diagram of host board connector block pin numbers and names

### 3.+3.3V Volt Electrical Power Interface

The SFP+-10GBASE-T has an input voltage range of 3.3 V +/- 5%. The 4V maximum voltage is not allowed for continuous operation.

+3.3 Volt Electrical Power Interface						
Parameter	Symbol	Min	Typ	Max	unit	Notes/Conditions
Supply Current	Is		700	900	mA	3.0W max power overfull range of voltageand temperature.See caution note below
Input Voltage	Vcc	3.13	3.3	3.47	V	Referenced to GND
Maximum Voltage	Vmax			4	V	
Surge Current	Isurge		TBD		mA	Hot plug above steady statecurrent. See caution notebelow

**Caution:** Power consumption and surge current are higher than the specified values in the SFP MSA

### 4. Low-Speed Signals

MOD\_DEF(1) (SCL) and MOD\_DEF(2) (SDA), are open drain CMOS signals (see section VII, "Serial Communication Protocol"). Both MOD\_DEF(1) and MOD\_DEF(2) must be pulled up to host\_Vcc

Low-Speed Signals, Electronic Characteristics					
Parameter	Symbol	Min	Max	unit	Notes/Conditions
SFP Output LOW	VOL	0	0.5	V	4.7k to 10k pull-up to host_Vcc,measured at host side of connector
SFP Output HIGH	VOH	host_Vcc -0.5	host_Vcc + 0.3	V	4.7k to 10k pull-up to host_Vcc,measured at host side of connector
SFP Input LOW	VIL	0	0.8	V	4.7k to 10k pull-up to Vcc, measured at SFP side of connector
SFP Input HIGH	VIH	2	Vcc + 0.3	V	4.7k to 10k pull-up to Vcc, measured at SFP side of connector

## 5.High-Speed Electrical Interface

All high-speed signals are AC-coupled internally.

High-Speed Electrical Interface, Transmission Line-SFP						
Parameter	Symbol	Min	Typ	Max	unit	Notes/Conditions
Line Frequency	fL		125		MHz	5-level encoding, perIEEE 802.3
Tx Output Impedance	Zout,TX		100		Ohm	Differential, for allfrequencies between1MHz and 125MHz
Rx Input Impedance	Zin,RX		100		Ohm	Differential, for allfrequencies between1MHz and 125MHz

High-Speed Electrical Interface, Host-SFP						
Parameter	Symbol	Min	Typ	Max	unit	Notes/Conditions
Single ended data inputswing	Vinsing	250		1200	mV	Single ended
Single ended data outputswing	Voutsing	350		800	mV	Single ended
Rise/Fall Time	Tr, Tf		175		psec	20%-80%
Tx Input Impedance	Zin		50		Ohm	Single ended
Rx Output Impedance	Zout		50		Ohm	Single ended

## 6.General Specifications

General						
Parameter	Symbol	Min	Typ	Max	unit	Notes/Conditions
Data Rate	BR	1		10	Gb/sec	IEEE 802.3 compatible.See Notes 1,2 below

Notes:

1.Clock tolerance is +/- 50 ppm

## 7. EEPROM INFORMATION (A0)

Addr	Field Size(Bytes)	Name of Field	HEX	Description
0	1	Identifier	03	SFP
1	1	Ext. Identifier	04	MOD4
2	1	Connector	22	RJ45
3-10	8	Transceiver	00 00 00 00 00 00 00 00	Transmitter Code
11	1	Encoding	06	64B66B
12	1	BR, nominal	67	10000M bps
13	1	Reserved	00	
14	1	Length (9um)-km	00	
15	1	Length (9um)	00	
16	1	Length (50um)	08	80
17	1	Length (62.5um)	03	30
18	1	Length (copper)	00	
19	1	Reserved	1E	30
20-35	16	Vendor name	57 49 4E 54 4F 50 20 2020 20 20 20 20 20 20 20	
36	1	Reserved	00	
37-39	3	Vendor OUI	00 00 00	
40-55	16	Vendor PN	XX XX XX XX XX XX XX XXXX XX XX XX XX XX XX XX	ASC II
56-59	4	Vendor rev	31 2E 30 20	V1.0
60-61	2	Wavelength	00 00	850nm
62	1	Reserved	00	
63	1	CC BASE	XX	Check sum of byte 0~62
64-65	2	Options	00 1A	LOS, TX_DISABLE, TX_FAULT
66	1	BR, max	00	
67	1	BR, min	00	
68-83	16	Vendor SN	00 00 00 00 00 00 00 00 0000 00 00 00 00 00 00 00 00	Unspecified
84-91	8	Vendor date code	XX XX XX 20	Year, Month, Day
92-94	3	Reserved	00	
95	1	CC_EXT	XX	Check sum of byte 64~94
96-255	160	Vendor specific		

8. EEPROM INFORMATION (A2) , optional

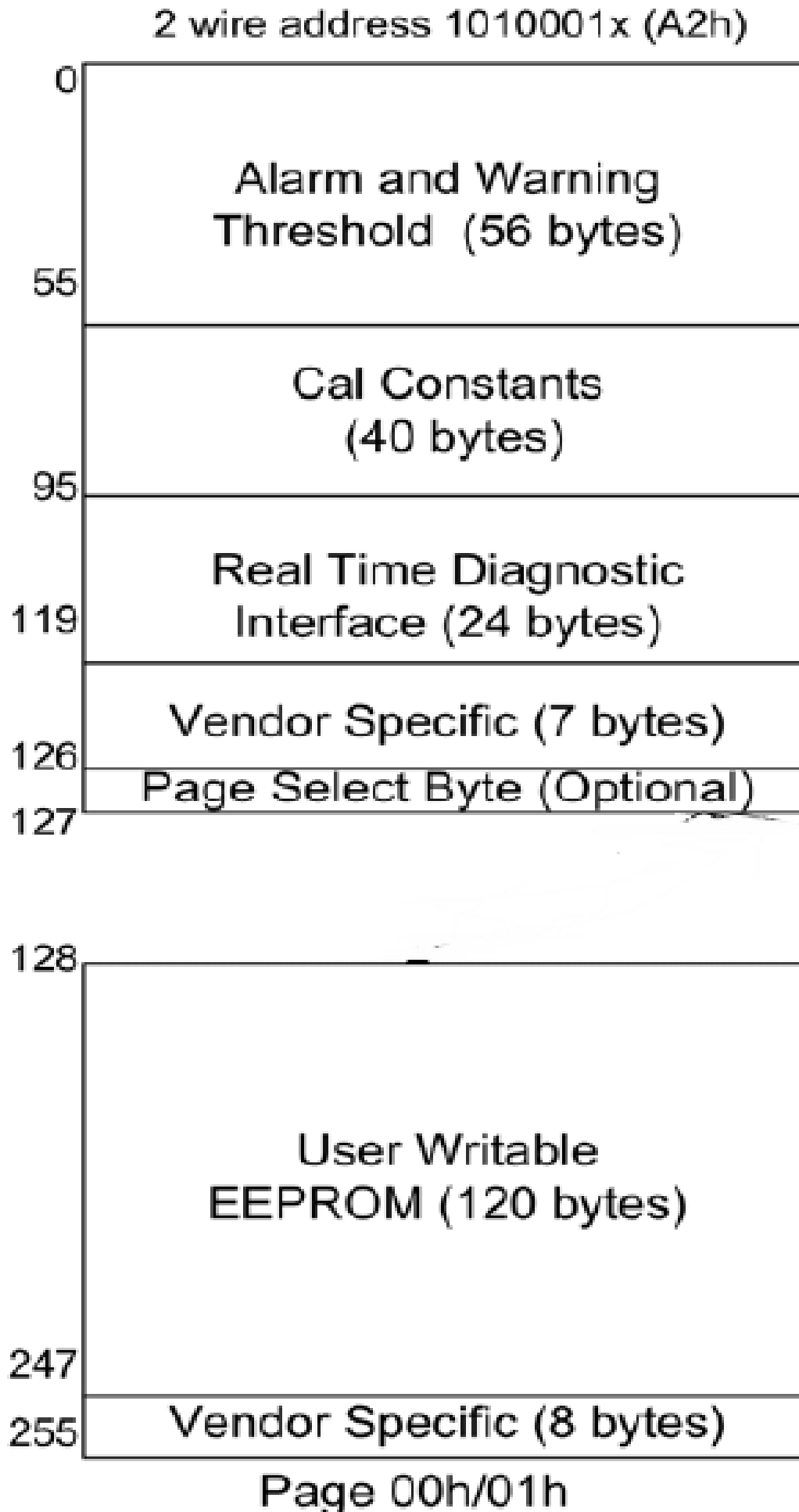

## 9.Environmental Specifications

Automatic crossover detection is enabled. External crossover cable is not required

Environmental Specifications						
Parameter	Symbol	Min	Typ	Max	unit	Notes/Conditions
Operating Temperature	Top	0		65	° C	Case temperature
Storage Temperature	Tsto	-40		85	° C	Ambient temperature

## 10. Serial Communication Protocol

All WINTOP SFPs support the 2-wire serial communication protocol outlined in the SFP MSA. These SFPs use an MCU, can be accessed with address of A0h.

Serial Bus Timing, Requirements						
Parameter	Symbol	Min	Typ	Max	unit	Notes/Conditions
I 2C Clock Rate		0		200,000	Hz	

## 11. Recommended Application Circuit

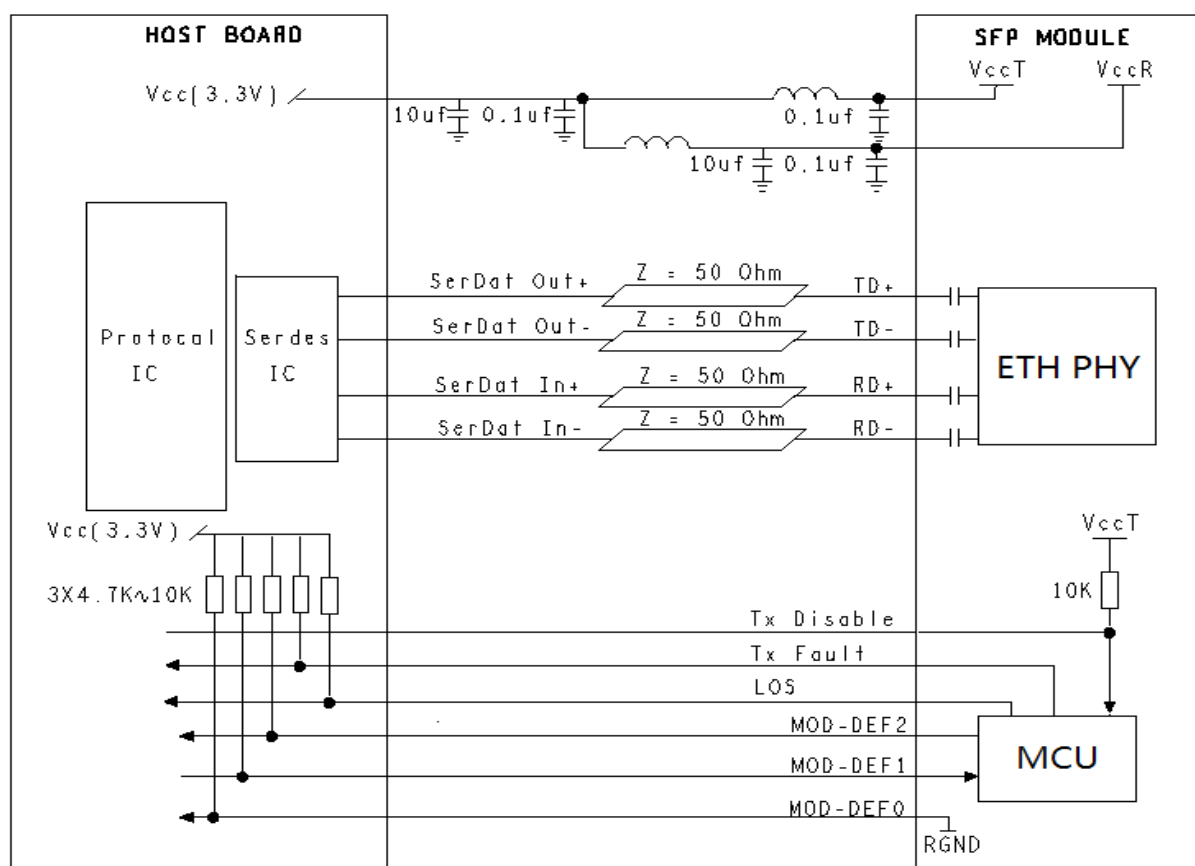



12. Mechanical Specifications (Unit:mm)

